

PYROT

KÖB

KRT 150 to KPT 1250

Wood Fired Boiler

Heating output: 150 to 540 kW / 512 to 1843 MBH

Min operation output: 45 to 140 kW / 154 to 478 MBH

Operation and Maintenance Instructions

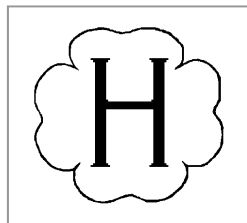

WARNING

If the information in this manual is not followed exactly, a fire or explosion may result causing property damage, personal injury or loss of life.

Do not store or use gasoline or other flammable liquids in the vicinity of this or any other appliance.

WHAT TO DO IF YOU SMELL FLUE GAS

- Deactivate heating equipment
- Open windows and doors.
- Inform your heating contractor

Installation and service must be performed by a installer or service agency



WARNING

Improper installation, adjustment, and/or operation could cause carbon monoxide poisoning resulting in injury or loss of life.

This product must be installed and serviced by an professional service technician who is experienced

IMPORTANT

Read and save these instructions
For future reference.

KÖB IS A PART OF THE VIESSMANN GROUP.

Pyrot oi/ mi 11/2008

VIESSMANN

Safety, Installation and Warranty Requirements

Please ensure that these instructions are read and understood before commencing installation. Failure to comply with the instructions listed below and detail printed in this manual can cause product / property / damage, severe personal injury, and / or loss of life. Ensure all requirements below are understood and fulfilled (including detailed information found in manual subsections).

■ Licensed' professional' heating contractor

The installation, adjustment, service, and maintenance of this equipment *must be* performed by a licensed professional heating contractor.

►" Please see section entitled "Important Regulatory and Installation Requirements".



■ Product documentation

Read all applicable documentation before commencing installation. Store documentation near boiler in a readily accessible location for reference in the future by service personnel.

►" For a listing of applicable literature, please see section entitled "Important Regulatory and Safety Requirements".



■ Advice to owner

Once the installation work is complete, the heating contractor must familiarize the system operator/ultimate owner with all equipment, as well as safety precautions/requirements, shut-down procedure, and the need for professional service annually before the heating season begins.

■ Contaminated air

Air contaminated by chemicals can cause by-products in the combustion process which are *poisonous* to inhabitants and destructive to Viessmann equipment.

►" For a listing of chemicals which cannot be stored in or near the boiler room, please see subsection entitled "Combustion air supply".



► Carbon monoxide
Improper installation, adjustment, service and/or maintenance can cause flue products to flow into living space. Flue products contain *poisonous* carbon monoxide gas.

" For information pertaining to the proper installation, adjustment, service and maintenance of this equipment to avoid formation of carbon monoxide, please see instructions supplied with burner.



■ Fresh air

This equipment requires fresh air for safe operation and must be installed ensuring provisions for *adequate combustion* and *ventilation air* exist.

►" For information pertaining to the fresh air requirements of this product, please see subsection entitled "Combustion air supply".

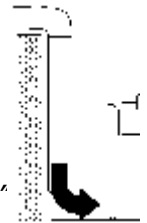

■ Equipment venting

Never operate boiler without an *installed venting system*. An improper venting system can cause carbon monoxide poisoning.

►" For information pertaining to venting and chimney requirements, please see section entitled "Venting Connection". All products of combustion must be safely vented to the outdoors.



■ Warranty

Information contained in this and related product documentation must be read and followed. *Failure to do so renders warranty null and void.*



WARNING

Installers must follow local regulations with respect to installation of carbon monoxide detectors. Follow manufacturer's maintenance schedule of boiler.

Safety, Installation and Warranty Requirement

■ Fiberglass wool and ceramic fiber Materials

 **WARNING**
Inhalation of fiberglass wool and/or ceramic fiber materials is a possible cancer hazard. These materials can also cause respiratory, skin and eye irritation.

The state of California has listed the airborne fibers of these materials as a possible cancer hazard through inhalation. When handling these materials, special care must be applied.

Suppliers of ceramic fiber products recommend the following first aid measures:

- *Respiratory tract (nose and throat) irritation*

If respiratory tract irritation develops, move the person to a dust free location.

- *Eye irritation*

If eyes become irritated, flush immediately with large amounts of lukewarm water for at least 15 minutes. Eyelids should be held away

from the eyeball to ensure thorough

insing. Do not rub eyes.

- *Skin irritation*

If skin becomes irritated, remove soiled clothing. Do not rub or scratch

exposed skin. Wash area of contact thoroughly with soap and water.

Using a skin cream or lotion after washing may be helpful.

- *Gastrointestinal irritation*

If gastrointestinal tract irritation develops, move the person to a dust free environment.

Suppliers of fiberglass wool products

recommend the following precautions

be taken when handling these materials:

Precautionary measures

- Avoid breathing fiberglass dust and contact with skin and eyes.

- Use NIOSH approved dust/mist respirator.

- Wear long-sleeved, loose fitting clothing, gloves and eye protection.

- Wash work clothes separately from

other clothing. Rinse washer thoroughly.

- Operations such as sawing, blowing, tearout and spraying may generate airborne fiber concentration requiring

additional protection.

First aid measures

- If eye contact occurs, flush eyes with

water to remove dust. If symptoms persist, seek medical attention.

- If skin contact occurs, wash affected areas gently with soap and warm water after handling

■ Hazardous materials

 **WARNING**
Appliance materials of construction, products of combustion and the fuel contain alumina, silica, heavy metals, carbon monoxide, nitrogen oxides, aldehydes and/or other toxic or harmful substances which can cause serious injury or loss of life and which are known to the State of California to cause cancer, birth defects and other reproductive harm. Always use proper safety clothing, respirators and equipment when servicing or working nearby the appliance.

Safety, Installation and Warranty Requirement



■ Take note of all symbols and notations intended to draw attention to potential hazards or important product information. These include "WARNING", "CAUTION", and "IMPORTANT". See below *important product information*.

 WARNING
Indicates an imminently hazardous situation which, if not avoided, could result in substantial property/product damage, serious personal injury, or loss of life.



Warnings draw your attention to the presence of potential hazards or information.



Helpful hints for Installation, operation or maintenance which pertain to the product.



This symbol indicates that additional, pertinent Information is to be found in the adjacent column

 CAUTION
Indicates an imminently hazardous situation which, if not avoided, may result in minor injury or product/property damage.



Cautions draw your attention to the presence of potential hazards or important product information.



This symbol indicates that other instructions must be referenced.

IMPORTANT



Contents

1	General Information	7
1.	Safety Requirements	7
1.1	Foreword	11
1.2	Technical standing	11
1.3	Intended use	11
1.4	Technical data	11
1.5	Information documented	11
1.6	CSA and ASME certification	11
2	Important Information	12
2.1	Safety instructions	12
2.2	Excess temperature/power failure	12
2.3	Low water/excess water pressure	12
2.4	A fire hazard	13
2.5	Wood fuels, minimum requirements	13
2.6	Filling the fuel storage unit	13
2.6.1	By dumping	13
2.6.2	By blowing in	13
2.7	Correcting malfunctions in the feed systems	13
3	How the Boiler Plant is Structured	14
4	Commissioning/Operation	15
4.1	The initial start-up	15
4.2	Operation	15
4.2.1	Heating up	15
4.2.2	Operation	15
4.2.3	Switching off	15
5	The ECOTRONIC control system	16
5.1	General information	16
5.1.1	Replacing the battery	16
5.2	The functions of the keys	16
5.3	Boiler and loader system (F3/F4)	17
5.3.1	The F3 KEY: "PYROT Parameters"	17
5.3.2	The F4 KEY: "PYROT Loader System"	18
5.4	Extended control systems F5 – F8 (optional)	19
5.4.1	Room heating system	19
5.4.2	Utility water heater	21
5.4.3	Air heater	22
5.4.4	Annex buildings	23
5.4.5	Pipelining	24
5.4.6	Additional heat generator	25
5.4.7	Solar	26

6	Cleaning/Maintenance	27
6.1	Boiler	27
6.2	Installing the displacement rods into the heat exchanger	29
6.3	Feed systems	30
7	Shutdown	30
8	Carrying out disposals	30

1 General Information

1.1 Important Regulatory and Safety Requirements

■ Operation

Before operating the boiler, make sure you fully understand its method of operation. Your heating contractor should always perform the initial start-up and explain the system. Any warranty is null and void if these instructions are not followed.

■ Working on the equipment

All personnel working on the equipment or the heating system must have the **proper qualifications** and hold all necessary licenses.

Ensure **main power** to equipment, heating system, and all external controls has been **deactivated**. **Close main oil or gas shut-off valve**. Take precautions in all instances to avoid accidental activation of power during service work.

■ Dangerous conditions

- Deactivate main power immediately.
- Close main gas or oil shut-off valve.

■ Flue gas smell

- Deactivate heating equipment.
- Open windows and doors.
- Inform your heating contractor.

 CAUTION
Incomplete combustion and poisonous gases result if the fresh air intakes in the mechanical room are closed. Never close these openings.

■ Combustion air and ventilation air openings

Ensure that combustion air openings and ventilation air openings in the mechanical room are open.

■ Technical information

Literature applicable to the PYROT:

- Installation Instructions
- Operating Instructions

IMPORTANT

Keep all literature in a safe place at the installation site. Contact Viessmann for additional copies.

■ Regular maintenance and service

The entire heating system must be cleaned and serviced on a regular basis by a qualified heating contractor or service agency to ensure reliable, energy-efficient, and environmentally friendly operation.

The build-up of soot on the heat exchanger raises the flue gas temperature and reduces efficiency.

Indirect-fired domestic hot waterstorage tanks (if installed) must be serviced within two years (at most) of the installation date, and regularly thereafter (see Service Schedule starting).

For an overview of scheduled service procedures, please see section entitled "Service Schedule".

 WARNING
The boiler must not be located in areas or rooms where chemicals are stored, or aggressive vapors from (i.e. bleach, hair spray, methyl chloride, carbon tetrachloride or perchloroethylene) or high dust levels or humidity levels are present. Heat exchanger corrosion might occur and reduce the lifetime of the boiler significantly. If above criteria are not properly observed and boiler damage results, any warranty on the complete boiler and related components will be null and void.

IMPORTANT

Keep boiler and boiler room clear and free from combustible materials, gasoline and other flammable vapors and liquids. Do not obstruct the flow of combustion and ventilation air. A qualified heating contractor must perform all inspection, maintenance and service.

WARNING

Improper installation, adjustment, service, or maintenance can cause flue products to flow into living space. Flue products contain poisonous carbon monoxide gas which can cause nausea or asphyxiation resulting in severe personal injury or loss of life.

WARNING

As there are no user-serviceable parts on the boiler, burners or control, the end-user must not perform service activities of any kind on system components. Failure to heed this warning can cause property damage, severe personal injury, or loss of life.

■ Important to know

Do **not** use this boiler if any part has been under, or exposed to, water. Immediately call a qualified heating contractor to inspect the boiler and to replace any part of the control system and any gas control which has been under, or exposed to water.

■ Carbon monoxide

The U.S. Consumer Product Safety Commission strongly recommends the installation of carbon monoxide detectors in buildings in which gas-burning equipment is installed. Carbon monoxide (CO) is a colorless, odorless gas, which may be produced during incomplete combustion of fuel and/or when the flame does not receive an adequate supply of combustion air.

Carbon monoxide can cause severe personal injury or loss of life.

Therefore, carbon monoxide detectors that are in compliance with a nationally recognized standard (e.g. ANSI/UL 2034-2002, CSA 6.19-01) should be installed and maintained in buildings that contain gas-burning equipment.

Note:

Viessmann does not test any detectors and makes no representation regarding any brand or type of detector.

■ For safe operation

We recommend that you frequently:

- Check for debris which could obstruct the flow of flue gases. The vent or chimney must not be blocked. A blocked or partially blocked vent or chimney can cause flue gases to leak into the structure. Flue gases leaking into the house can cause injury or death. Blocked or partially blocked chimneys must have the blockage removed by a qualified heating contractor.
- Check pressure gage for correct system (water) pressure. Check for water on the floor from the discharge pipe of the pressure relief valve or any other pipe, pipe joint, valve or air vent.
- Check for moisture, water, or appearance of rust on the flue gas pipes, their joints as well as vent dampers, or side wall vent terminals (if so equipped).
- Ensure that nothing is obstructing the flow of combustion and ventilation air and no chemicals, garbage, gasoline, combustible materials, flammable vapors and liquids are stored (not even temporarily) in the vicinity of the boiler.
- Do **not** allow unsupervised children near the boiler.

Service/inspection of the boiler and the system is recommended once a year. Maintenance, service and cleaning are specified in the Installation Instructions.



WARNING

As there are no user-serviceable parts on the boiler, burner or control, the end-user must not perform service activities or adjustments of any kind on system components. Failure to heed this warning can cause property damage, severe personal injury, or loss of life.



WARNING

Improper installation, adjustment, service, or maintenance can cause flue products to flow into living space. Flue products contain poisonous carbon monoxide gas which can cause nausea or asphyxiation resulting in severe personal injury or loss of life.



WARNING

Failure to protect against frozen pipes could result in burst water pipes, serious property damage and/or personal injury. Boiler may shut down. Do not leave your home unattended for long periods of time during freezing weather conditions without turning off the water supply and draining water pipes or otherwise protecting against the risk of frozen pipes.

Your heating boiler is designed to provide a warm and comfortable living environment. It is NOT designed to ensure against freezing of water pipes. The boiler is equipped with several safety devices that are designed to shut down the boiler and to prevent it from restarting in the event of various unsafe conditions.

If your boiler remains off for an extended period of time during cold weather, water pipes may freeze and burst, resulting in extensive water damage and conditions in which mold could grow. Certain molds are known to cause respiratory problems, as well as to pose other serious health risks. In case of water damage, immediate measures should be taken to dry out affected areas as quickly as possible to prevent mold from developing.

If your home will be unattended for an extended period of time during cold weather, you should...

■ Shut off the water supply to the building, drain the water pipes and add antifreeze for potable water to drain traps and toilet tanks. Open faucets where appropriate.

Or...

■ Have someone check the building frequently during cold weather and call a qualified service agency if required.

Or...

■ Install a reliable remote temperature sensor that will notify somebody of freezing conditions within the home.

If you notice fire coming from the appliance, call the fire department immediately! Do not attempt to extinguish the fire unless qualified to do so.

■ Installation area conditions



WARNING

Incorrect ambient conditions can lead to damage to the heating system and put safe operation at risk.

■ Ensure ambient temperatures are higher than 50°F / 10°C and lower than 104°F / 40°C.
■ Prevent the air from becoming contaminated by homogenate hydrocarbons (e.g. as contained in paints solvents or cleaning fluids) and excessive dust (e.g. through grinding or polishing work). Combustion air for the heating process, and ventilation of the boiler room must be free of corrosive contaminants. To that end, any boiler must be installed in an area that has no chemical exposure. The list to the right indicates the main, currently known sources.

■ Avoid continuously high levels of humidity (e.g. through frequent drying of laundry).

■ Never close existing ventilation openings.

Replacement components, spare and wear parts.

IMPORTANT

Components, which are not tested with the heating system may damage the heating system, or affect its functions. A qualified heating contractor may only carry out installation or replacement.

Sources of combustion and ventilation air contaminants

■ Areas likely to contain contaminants:

- ▶ New building construction
- ▶ Swimming pools
- ▶ Remodeling areas, hobby rooms
- ▶ Garages with workshops
- ▶ furniture refinishing areas
- ▶ Dry cleaning/laundry areas and establishments
- ▶ Auto body shops
- ▶ Refrigeration repair shops
- ▶ Metal fabrication plants
- ▶ Plastic manufacturing plants
- ▶ Photo processing plants
- ▶ Beauty salons

■ Products containing contaminants:

- ▶ Chlorine-type bleaches, detergents and cleaning solvents found in household laundry rooms
- ▶ Paint and varnish removers
- ▶ Hydrochloric acid, muriatic acid
- ▶ Chlorine-based swimming pool chemicals
- ▶ Spray cans containing chlorofluorocarbons
- ▶ Chlorinated waxes and cleaners
- ▶ Cements and glues
- ▶ Refrigerant leaks
- ▶ Calcium chloride used for thawing
- ▶ Sodium chloride used for water softening salt
- ▶ Permanent wave solutions
- ▶ Adhesives used to fasten building products and other similar items
- ▶ Antistatic fabric softeners used in clothes dryers

■ Product information

High efficiency with reduced emissions

Viessmann solid-fuel boiler may only be set up and commissioned by specialists. This will rule out any incorrect assembly or commissioning. These instructions have thus been reduced to important technical data, references to regulations, technical rules and other regulations.

Steel - wood fired hot water heating boiler.

For operation with modulating boiler water temperatures in closed and open loop forced circulation hot water heating systems.

The Pyrot KRT boilers are certified the CAN/CSA B366.1-M91 and UL 391.

The boiler model selected should be based on an accurate heat loss calculation of the building. The boiler selected must be complete with the connected radiation.

Maximum working pressure 30 or 60 psig

Maximum boiler temperature 250 °F
(closed loop)

Maximal boiler temperature 290 °F
(open loop)

This boiler does not require a flow switch.

■ For optimum operation

To ensure optimum operation of your heating system do the following:

■ Keep the boiler and the boiler room clean and free of dust and dirt.

Ensure proper and adequate system pressure by occasionally checking the pressure gage.

■ Have a qualified heating contractor service and maintain your heating system on a regular basis. See Service Schedule.

WARNING

The boiler must not be located in areas or rooms where chemicals are stored, or aggressive vapors from (i.e. bleach, hair spray, methyl chloride, carbon tetrachloride or perchloroethylene) or high dust levels or humidity levels are present. Heat exchanger corrosion might occur and reduce the lifetime of the boiler significantly. If above criteria are not properly observed and boiler damage results, any warranty on the complete boiler and related components will be null and void.

1.1 Foreword

Dear System Owner, you have made a good selection in the PYROT. It will provide you with all the advantages of a modern, economically efficient heating system. Fully developed technology in combination with a sturdy design guarantees a high degree of operational reliability and a long service life.

These Operating and Maintenance Instructions contain important information for the intended use, correct operation and proper maintenance of the PYROT.

Non-compliance with the Operating and Maintenance Instructions will result in loss of the guarantee.

If you still need any further information after studying the Operating and Maintenance Instructions:

The Assembly and Installation Instructions contain important information about:

- Standards and regulations
- Structural surroundings of the boiler plant
- Transport and assembly
- Water installation and electrical installation
- Fire protection
- Commissioning

as well as an appendix with diagrams of connections and dimensions and the complete technical specifications.

Our sales and services offices will be glad to provide you with any further information. Their addresses can be found on the reverse side of these Operating and Maintenance Instructions.

1.2 Technical standing

The Operating and Maintenance Instructions are in keeping with the PYROT at the time it is delivered. In the interest of our customers, we reserve the right to make, without any notification requirement, subsequent changes resulting from further technology developments.

1.3 Intended use

The intended use of the PYROT is for incinerating wood fuels.

The intended use of the PYROT is stipulated:

- in the regulations of the Assembly and Installation Instructions
- by the limits of the technical specifications
- in Spec Sheet 1010 "Minimum Requirements for Wood Fuels/Instructions"
- by the safety regulations in these Operating and Maintenance Instructions.

Any other use of the PYROT or use of it going beyond this will be considered as unintended use unless written approval by the manufacturer has been obtained.

- Operation of the PYROT by unqualified personnel, without any training or knowledge of the Operating and Maintenance Instructions.

- Disabling the safety or monitoring devices on the PYROT.
- Removal of any protective covers or cladding on the PYROT by unauthorised individuals.
- Making any conversions or alterations to the PYROT without approval by the manufacturer.
- Using spare parts or accessories from other manufacturers without approval by the manufacturer.

The operating organisation will be liable for any damage or accidents in case of any unintended use.

1.4 Technical data

The following important limit values apply to the PYROT heating boiler:

Maximum working pressure	30 or 60 psig
Maximum boiler temperature (closed loop)	250 °F

The complete technical specifications are listed in the appendix of the Assembly and Installation Instructions.

1.5 Information documented

The installation instructions contain the information required according to the subject boilers have been tested and examined in accordance with:

CSA B366.1-M91
Solid Fuel Fired Central Heating Appliances

CSA C.22.2#3-M88(R2004)
Electrical Features of Fuel Burning Equipment

UL391 (4thEd)
Solid Fuel and Combination-Fuel Central and Supplementary Furnaces

CSA B365-01
Installation Code for Solid Fuel Burning Appliances and Equipment

1.6 CSA and ASME certification

The PYROT is delivered with a CSA and ASME on its Rating plate.

2 Important Information

2.1 Safety instructions

When carrying out work on the heating system, such as cleaning and maintenance, wear appropriate protective equipping when required.

There is a danger of getting injured through: burning, knocking against corners and edges, crushing in moving parts and noise.

Mains supply: 120V or 240V/1/ and 208V/3/ 60Hz

In a risky situation, the PYROT can be disconnected from the electrical mains at all the leads by the master switch on the control cabinet

Doors

For safety keep firing and ashpit doors tightly closed.

CAUTION

FIRE HAZARD:

The boiler must never be operated with the doors open!
Any burning bits that escape could start fire.

2.2 Excess temperature/power failure

CAUTION

DANGER OF THIS SUDDENLY GOING UP IN FLAMES:

Do not open the doors or lids on the boiler plant!

- Switch on additional heat loads.
- The flue gas fan goes out of operation.
- The temperature-limiting safety switch triggers.
- The valve for the thermal run-off safety valve opens at approx. (95°C) 203° F. The excess heat is conducted off into the channel.

If the temperature-limiting safety switch (FHL) has triggered, then it has to be manually unlocked. The FHL is situated at the top of the boiler.

To reset, unscrew the black cap and press the button.

NOTE: Only as of a temperature of approx. (70°C) 158°F resetting is possible.

Possible causes for excess temperature:

- Incorrect setting on the control module.
- Defective component of the system (pump or valve).
- Sudden drop in output to zero. The feed auger still has to be emptied. The heat yet produced by this can result in surplus temperature. Activate "DISSIPATE SURPLUS HEAT" function!

RISK OF INJURY:

If the doors are open during operation, sparks or flames could leap out.

Equipment for dissipating excess heat

A competent specialist should examine the operational reliability of the thermal run-off safety valve annually. The safety heat exchanger must not by any means be used as an operational heat exchanger.

Seals

For the functioning and controllability of the burner, it is important that no unwanted air can leak in, entering unchecked through leaky spots.

The doors and lids have to shut tight – any damaged seals must be replaced immediately. Tighten the retaining screws and handles snugly.

Operation, cleaning & maintenance

Bear in mind that only if operated and maintained properly can even the best of products fulfil their functions well, doing so for a long time and free of malfunctions.

Compliance with the "Cleaning" section is mandatory!

2.3 Low water/excess water pressure

Possible causes:

1. Low water: Leakage in the heating system.
2. Excess water pressure: The expansion tank not functioning.

In either case, should the boiler examined by a competent heating constructor.

Unlock this malfunction with either the reset button for the water level control system or for the overpressure monitor, and by pressing the OK key on the control panel.

2.4 A fire hazard

With insertion-type firing systems, the conveying route creates a connection between the silo and the burning material in the boiler plant.

With the PYROT insertion-type heating boiler, the feed auger is also the metering auger, and is thus always filled up with material during operation. There are various safety devices provided to prevent burn-back.

Temperature sensors:

By means of temperature sensors on the feed auger, in case of excess temperature the loading to the feed auger is interrupted, and the feed auger's material is inserted into the combustion chamber.

Slide valve (optional):

This closes in case of a standstill, danger of burn-back or power failure (spring return motor).

valve (optional):

Instead of a slide valve, in silos with pressurisation.

Drop-off route:

A vertical drop-off section interrupts the connected line of burning material.

Fire-extinguishing system (option):

This system, which functions independently of the electrical power, brings about a flooding of the material to be burned that is located in the feed auger. The activation temperature is approx. (95°C) 200°F.

2.5 Wood fuels, minimum requirements

The PYROT is only suitable for incinerating the fuels listed in Spec Sheet 1010 "Minimum Requirements for Wood Fuels" (see supplement).

If different fuels are used, Viessmann will not assume any liability for the functioning or service life of the boiler plant. Refer to the "Warranty" section in the General Terms and Conditions of Delivery.

- Born wood only
- Do not use chemicals or fluids to start fire.
- Do not burn garbage, gasoline, naphtha, engine oil, or other inappropriate materials.

2.6 Filling the fuel storage unit

When storage facilities for wood are required, the wood should be kept at least (1.5m) 5ft from the heating appliance.

2.6.1 By dumping

Rotary sweep extraction and spring-operated extraction

Heating system in operation:

- If the articulated arms or spring-mounted plates are still covered by fuel, refilling can be carried out immediately.
- If the articulated arms or spring-mounted plates are no longer covered by fuel, fill the silo evenly to approx.

(30 cm) 1ft above the articulated arm or over the spring-mounted plates. As soon as the articulated arms or spring-mounted plates have retracted through a request for material, the refilling can be continued.

Heating out of operation:

- If the articulated arms or spring-mounted plates are still covered by fuel, refilling can be carried out immediately.
- If the articulated arms or spring-mounted plates are no longer covered by fuel, fill the silo evenly to approx. (30 cm) 1ft above the articulated arm or over the spring-mounted plates. Then activate the "SILO FILLING" function. To do so, press the LOADER SYSTEM key (F4) and then the left arrow key (<). Then select "YES" and confirm with "OK". Wait until the articulated arms or the spring-mounted blades go under the cup washer, and then finish evenly filling the silo. The "SILO FILLING" function brings about the filling of the fire box.

NOTE: The "SILO FILLING" function cannot be activated until the heating system has been out of operation for one hour.

Moving floor conveyor

- Fuel can be refilled automatically.

Funnel extraction system

- It is mandatory that the heating system be in operation!

2.6.2 By blowing in

The heating system has to be out of operation (danger of excess pressure or negative pressure caused by the action of blowing-in). Filling procedure as described in section 2.6.1.

2.7 Correcting malfunctions in the feed systems

The cause of motor malfunctions in feed systems is usually clogging by large pieces of wood or foreign matter.

CAUTION

DANGER OF INJURY:

Always turn off the master switch before carrying out any repair of a malfunction on feed systems and every time before a maintenance lid is opened or a protective device is removed!

The automatic operation of the system makes it impossible to foresee the time point when the conveying equipment will switch on.

3 How the Boiler Plant is Structured

(Illustration: PYROT 300)

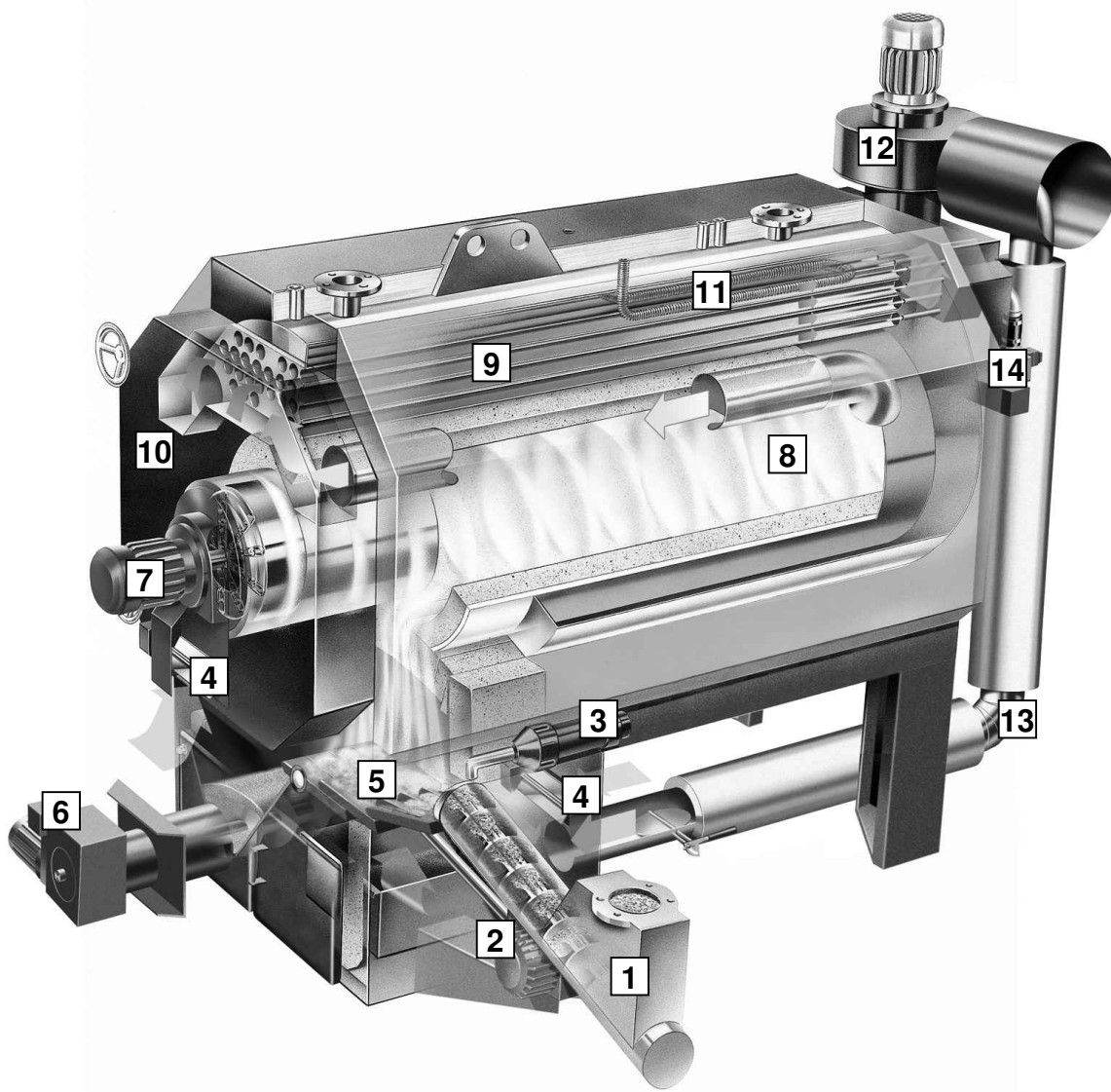

- | | |
|---|---|
| (1) Feed auger with isolating layer | (8) Rotation combustion chamber (Viessmann-pat ented) |
| (2) Drive for moving grate | (9) Boiler heat exchanger |
| (3) Automatic ignition device | (10) Boiler door |
| (4) Controlled combustion air supply system | (11) Heat exchanger for thermal run-off safety valve |
| (5) Moving grate | (12) Speed-controlled exhaust fan |
| (6) Drive for automatic de-ashing system (optional) | (13) Recirculated flue gas pipe (optional) |
| (7) Rotation fan (Viessmann-patented) | (14) Automatic cleaning system (optional) |

4 Commissioning/Operation

4.1 The initial start-up

Only Viessmann or another trained specialist may put a newly installed facility into operation for the first time.

Be absolutely sure to follow the instructions in the Assembly and Installation Instructions. No warranties may be claimed for damages in cases of initial start-ups carried out improperly at one's own initiative.

First check:

- Is there enough water in the heating system?
- Has the heating system been bled of air?
- Are the slide valves open for the heating-system's forward and reverse flow?
- Can enough fresh air get into the heating room?
- Empty ash bin.
- Are the doors and lids on the burner all closed leak-tight?
- For safety keep firing and ashpit doors tightly closed.

4.2 Operation

4.2.1 Heating up

- Press the F1 key "PYROT Wood". The loader modules will be switched on in the appropriate order. When there is enough fuel in the combustion chamber, the entire loader system switches off.
- The automatic ignition then takes place. The ignition process stops as soon as the fire is started.

4.2.2 Operation

- The material is supplied depending on the light barriers in the metering container and in the combustion chamber, allowing for the residual oxygen.
- The primary and secondary air vents change their positions depending on the exhaust gas temperature and residual oxygen.
- Using the setting "Storage Management, Temperature, Storage, Average", it is possible to keep the facility in continuous high-performance operation for as long as possible – with fewer ignitions, better efficiency and lower emissions.
(Only possible with accumulator option)
- When the boiler temperature set is reached, the facility switches to "Run Auger Empty". When the feed auger has been run empty, and the exhaust gas temperature is less than (90°C) 194°F, the exhaust gas fan switches off and the air vents close.

- When the "System Temperature Setting" is fallen short of, the boiler is automatically started back up.

4.2.3 Switching off

- Press the F1 key "PYROT Wood". As feedback to this, "Run Auger Empty" will appear on the control panel.

CAUTION: Do NOT use the master button to switch off (DANGER OF BACK BURN) !!!

5 The ECOTRONIC control system



5.1 General information

The ECOTRONIC facility control system is a decentralised microprocessor system (CAN-BUS) developed by KÖB with various modules that are connected by a data transmission line.

Its function

The ECOTRONIC records all the data relevant to operation and controls the supply of and demand for heat.

Thus the boiler plant is continuously monitored during all the operating phases and kept within an optimum range in terms of emissions.

F5 (Group 1)

Setting parameters and set point values
(heat distribution, Group 1)

F6 (Group 2)

Setting parameters and set point values
(heat distribution, Group 2)

F7 (Group 3)

Setting parameters and set point values
(heat distribution, Group 3)

F8 (Group 4)

Setting parameters and set point values
(heat distribution, Group 4)

< Go one page to the left in menu masks

> Go one page to the right in menu masks

^ Go one line up
(Only possible when the scroll up symbol ↑ is displayed.)

∨ Go one line down
(Only possible when the scroll down symbol ↓ is displayed.)

+ Change numeric values and set point values

- Change numeric values and set point values

Factory settings (pre-settings)

All the parameters in the ECOTRONIC, such as set point values and switching times, are pre-set and can be called back up at any time. The figures for the factory settings are given in brackets for the various parameters.

5.1.1 Replacing the battery

There is a battery built in beneath the removable lid on the control module (type: Panasonic Lithium BR2330). It is for buffering the time, date and settings.

- The battery needs replacing every five years!
- Do not disconnect the mains voltage while changing the battery (do not turn off master switch)!

5.2 The functions of the keys

F1 (PYROT Wood)

Switch WOOD operation on and off

F2 (PYROT Oil)

Switch OIL OPERATION on and off

F3 (PYROT Parameters)

Setting parameters, set point values, the date and time

F4 (PYROT Loader System)

Setting of cycle switchover switching, advance-flow and post-flow times

OK Adopt (acknowledge) settings and/or changes

The following applies to the F3, F4, F5, F6, F7 & F8 buttons:

- Pressing once will take you to the respective menu. As feedback, the relevant LED will blink.
- If a set point value is changed and not confirmed with "OK", then it will not be adopted.
- Pressing the function button again will bring back the standard display.
- When no button is pressed for a period of sixty seconds, the standard display automatically reappears.

BE SURE TO NOTE:

Depending on the design and setting, some menus and texts do not appear.

5.3 Boiler and loader system (F3/F4)

5.3.1 The F3 KEY: "PYROT Parameters"

(screen number) parameter (factory setting)

(01) Storage unit temperatures (-):

Indication of all the storage unit temperatures
(Indication only for storage unit option)

(02) Return flow, boiler (70°C):

Set point value for boiler backflow circuit valve

(03) Forward flow, boiler (80°C):

Set point value for boiler temperature

(04) Exhaust gas, boiler (200°C):

Limit of maximum exhaust gas temperature

(05) Exhaust gas, residual O2 (7%):

Set point value for residual oxygen for air vent control

(06) O2-control (ON):

If the lambda sensor is defective, the O2-control system can be switched off (emergency operation).

(07) Air vents without O2-control system (100%):

Position of the air vents with O2-control switched off (only with O2-control system switched off)

(08) Carry away excess heat at (95°C):

Limit temperature for carrying away excess heat

(16) Storage Unit Management, Temperature, Storage Unit Average (80°C):

Set point value, average temperature, storage unit
→ boiler output is reduced according to loading of storage unit. (Indication only for storage unit option)

(17) Start boiler when the system temperature is fallen short of. Set point (accumulator sensor at bottom):

When the accumulator sensor falls short of the system set point, the boiler will be heated up.
(Indication only for storage unit option)

(20) External release for boiler (NO):

Is the boiler to be switched on and off by an external floating contact?

(25) Pneumatic boiler tube cleaning system (500 s):

Cleaning cycle for the pneumatic cleaning system

(28) Wood operation, load (0):

Operating hours/minutes, full load, PYROT

(30) Oil/Gas operation (0):

Operating hours/minutes, oil/gas operation, PYROT ECO

(31) Date/Year (current):

Set year

(10) Load storage unit with oil/gas operation to (storage unit at bottom):

To which heat storage sensor should the storage unit be loaded with oil/gas operation?
(Indication only with option of storage unit and oil/gas burner on PYROT ECO)

(11) Load storage unit with oil/gas operation to (70°C):

To what temperature should the storage unit be heated up with oil/gas operation?
(Indication only with option of storage unit and oil/gas burner on PYROT ECO)

(12) System Temperature Set Point Minimum (50°C):

Minimum forward flow temperature for heat distribution provided by customer (only if System Temperature Set Point Minimum YES → Service Menu)

(14) Load storage unit to (STORAGE UNIT AT BOTTOM):

To which heat storage sensor should the storage unit be loaded with wood operation?
(Indication only for storage unit option)

(15) Load storage unit to (80°C):

To what storage unit temperature should the storage unit be heated up with wood operation?
(Indication only for storage unit option)

(Indication only with the option "Automatic Start, External Prompt".)

(21) Material take-back larger with air vent positioning (50%):

Material take-back by means of adjustable air vent positioning.

(23) Feed auger cycle heat-up (5%):

Insertion of material after ignition

(24) Feed auger, maximum (100%):

Maximum insertion of material

(32) Date/Month (current):

Set month

(33) Date/Day (current):

Set day

(34) Date/Day of week (current):

Set day of week

(35) Date/Hours (current):

Set hours

(36) Date/Minutes (current):

Set minutes

(40) Enter permanent code (-):

(41) Measurement operation (NO):

This activates measurement operation for chimney sweep measurements.

IMPORTANT: The control of output is then not functioning: provide for sufficient thermal acceptance.

5.3.2 The F4 KEY: "PYROT Loader System"

(screen number) parameter (factory setting)

(01) Cleaning (NO):

This activates the cleaning function. Exhaust fan at starting speed, and moving grate on.

(05) Moving grate, pause (60 s):

Cycle switching for the moving grate (adjustable pause time, impulse fixed, 2 seconds).

(07) Metering container, empty running time (5s):

Running time for feed auger with the light barrier for the feed auger clear → prompt for material

(08) Conveyor Device 1/Delay (3 s):

Delay before connecting Conveyor System 1 (e.g. rotary valve, conveyor auger, etc.)

(09) Conveyor System 1, after-running (0 s):

After-running of Conveyor System 1 (e.g. pneumatic conveyor, etc.)

(10-37) Conveyor Systems 2-15:

Delay before connecting or after-running of Conveyor Systems 2 to 15

(38) Extraction System 1/Delay (3 s):

Delay before connecting Conveyor System 1

(e.g. spring-operated extraction system, inclined extraction system, etc.)

(39) Extraction System 1/Impulse (5 s):

Impulse for the cycle switching for Extraction System 1 (e.g. spring-operated extraction system, inclined extraction system, etc.)

(40) Extraction System 1, Pause (0 s):

Pause in the cycle switching for Extraction System 1 (e.g. spring-operated extraction system, inclined extraction system, etc.)

(41) Extraction System 2/Delay (3 s):

Delay before connecting Conveyor System 2 (e.g. spring-operated extraction system, inclined extraction system, etc.)

(42) Extraction System 2/Impulse (5 s):

Impulse for the cycle switching for Extraction System 2 (e.g. spring-operated extraction system, inclined extraction system, etc.)

(43) Extraction System 2, Pause (0 s):

Pause in the cycle switching for Extraction System 2 (e.g. spring-operated extraction system, inclined extraction system, etc.)

(44) Extraction System 1/Hydraulics/Delay

(5 s): Delay before connecting hydraulic drive for Extraction System 1

(45) Extraction System 2/Hydraulics/Delay

(5 s): Delay before connecting hydraulic drive for Extraction System 2

(50) Silo filling: Start silo filling (only possible when the facility is not in operation and has cooled off).

5.4 Extended control systems F5 – F8 (optional)

The F5 to F8 keys are assigned customer-specific extended control systems as desired. Each extended control system is assigned a separate key.

5.4.1 Room heating system

Function (ECO-H):

Weather-controlled regulation of heating with digital timer for lowerable operation according to a daily or weekly programme, with pump control, frost protection function, ECOcircuit and limited supply temperature.

Operating modes

- **Off:**
The room heating system is switched off.
- **Day/Night:**
Heating operation according to clocked programme. Normal temperature during the day and reduced temperature at night.
- **Day/Off:**
Heating operation according to clocked programme. Normal temperature during the day and switched off at night.
- **Day:**
Normal temperature continuously.
- **Night:**
Reduced temperature continuously.
- **Manual:**
Pump on; the valve is not controlled (emergency operation).

(screen number) parameter (factory setting)

(01) Operating mode (Day/Night)

Select operating mode

(02) Number of heating periods (1)

The weekly programme has to be entered in the form of heating periods. Each weekly programme consists of the heating day, start and end. A maximum of seven heating periods is available.

(03) Heating Period 1/Heating days (MON to SUN)

Day or days on which the switching times apply. Select the heating days with KEYS F1 (for Mon-day) to F7 (for Sunday). Pressing the button once → selects the day, pressing the button again → drops the day.

(04) Heating Period 1/Start (6:00)

Time to switch from lowered temperature (or off) to normal temperature.

(05) Heating Period 1/End (22:00)

Time to switch from normal temperature (or off) to lowered temperature.

(06-23) Heating Periods 2-7

These depend on the number of heating periods (see Mask 2), consisting of heating days, start and end.

(24) Temperature of flow/at +5°C (43°C)

Desired flow temperature at atmospheric temperature of +5°C (see heating curve).

(25) Temperature of flow/at -15°C (64°C)

Desired flow temperature at atmospheric temperature of -15°C (see heating curve).

(26) Temperature Room Day (20°C)

Setting for temperature of room during daytime operation.

(27) Temperature Room Night (15°C)

Setting for temperature of room during nighttime operation.

(28) Night-time lowering of flow temperature by (-6°C)

This temperature set is subtracted from the flow temperature calculated for night-time lowering.

(29) Flow temperature; maximum (70°C)

The maximum limit for the flow temperature.

(30) ECOcircuit (YES)

The ECO automatic savings system makes the heating switch on and off as required.

(31) Switch off below system temperature (NO)

Should the room heating unit group be switched off when a minimum system temperature is fallen short of?

(32) Frost protection function (YES)

With the frost protection function switched on, the room heating unit is turned on when there is a danger of frost.

(33) Carry off excess heat (NO)

If the PYROT is at risk of overheating, there is the option of the excess heat being carried off. The room unit adjusts to "Flow temperature/Maximum".

The heating curve

The correspondence of the flow temperature to the outdoor temperature can be set directly and read directly. The setting is carried out by two points:

Point 1:

Flow temperature at atmospheric temperature of +5°C (setting range from 20°C to 90°C).

Point 2:

Flow temperature at atmospheric temperature of -15°C (setting range from 20°C to 90°C).

IMPORTANT:



Point 2 always has to be set higher than Point 1!

The two points marked indicate the factory setting. Point 1 is set to 43°C and Point 2 to 64°C. This is equivalent to a steepness of approx. 1.5.

Room thermostat (ECO-ZR-QA):

The Model QAA 35 Room Thermostat can be used with or without influence by the room temperature.

Switch positions possible:

- Position:  Auto
Heating operation according to clocked programme as set in the ECOTRONIC.
- Position: 
Normal temperature continuously.
(The operating mode set in the ECOTRONIC will be ignored.)
- Position: 
Reduced temperature continuously.
(The operating mode set in the ECOTRONIC will be ignored.)

(Diagram: Heating Curve)

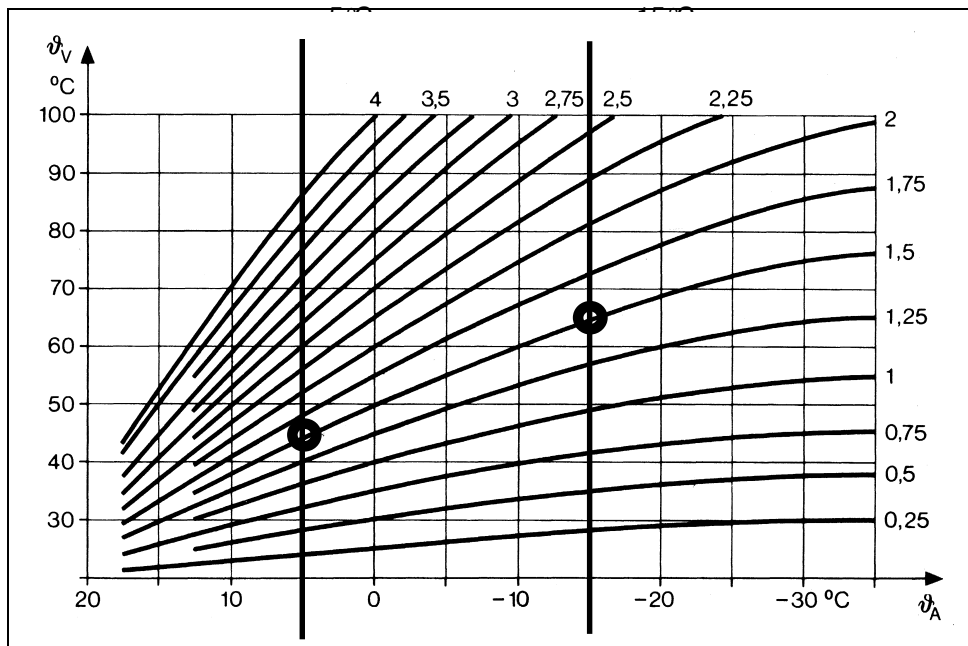

5.4.2 Utility water heater

Function:

- ECO-B1

When the temperature of the utility water drops, it is reheated by the built-in heat exchanger from the heat accumulator (hydraulic switcher). The condition for this is a relevant difference in temperature (choice of control according to temperature difference or fixed temperature).

The heating periods (daily and weekly programmes) can be set using the integrated timer.

- ECO-B2

When the temperature of the utility water drops, it is reheated by the built-in heat exchanger from the heat accumulator (hydraulic switcher). The condition for this is a relevant difference in temperature (choice of control according to temperature difference or fixed temperature).

The flow rate of the heating water is controlled by the return temperature (quantity control). This produces optimum storage stratification with long-lasting high temperature on the storage unit flow pipe.

The heating periods (daily and weekly programmes) can be set using the integrated timer.

Operating modes:

- Off:

The utility water heating system is switched off.

- Timer:

Utility water heating following clocked programme. (The boiler is only warmed up during the heating period.)

- On:

The boiler is heated up when prompted for heat and when there is sufficient system temperature.

- Manual:

Pump on; the valve is not controlled (emergency operation).

(screen number) parameter (factory setting)

(01) Operating mode (timer)

Select operating mode

(02) Number of heating periods (1)

The weekly programme has to be entered in the form of heating periods. Each weekly programme consists of the heating day, start and end. A maximum of seven heating periods is available.

(03) Heating Period 1/Heating days (MON to SUN)

Day or days on which the switching times apply. Select the heating days with KEYS F1 (for Mon-day) to F7 (for Sunday). Pressing the button once → selects the day, pressing the button again → drops the day.

(04) Heating Period 1/Start (6:00)

Start, clearance, utility water heating.

(05) Heating Period 1/End (22:00)

End, clearance, utility water heating

(06-23) Heating Periods 2-7

These depend on the number of heating periods (see screen 2), consisting of heating days, start and end.

(24) Temperature of utility water (60°C)

Set the desired temperature of the utility water.

Additional parameters for ECO-B2

(screen number) parameter (factory setting)

- Temperature of return flow ___°C higher than the temperature of the utility water (20°C)

Desired set-point temperature of return flow: actual boiler temperature plus the amount set here.

5.4.3 Air heater

Function (ECO-L):

The air heaters are supplied at maximum flow temperature from the boiler plant storage system. The fans are connected by switches or controllers provided by the customer. The flow rate of the heating water is controlled by the temperature of the return flow and thus adjusted to the air heater's thermal output (quantity control). This produces optimum storage stratification with long-lasting high temperature on the storage unit flow pipe. The heating periods (daily and weekly programmes) can be set using the integrated timer.

Operating modes:

- **Off:**
The air heater is switched off
- **Day/Off:**
Heating operation according to clocked programme. During the day the system is adjusted to the set point value for return flow, and at night it is off.
- **Day:**
Adjusted to the set point value for return flow (continuous operation).
- **Manual:**
Pump on; the valve is not controlled (emergency operation).

(screen number) parameter (factory setting)

(01) Operating mode (Day/Off)

Select operating mode

(02) Number of heating periods (1)

The weekly programme has to be entered in the form of heating periods. Each weekly programme consists of the heating day, start and end. A maximum of seven heating periods is available.

(03) Heating Period 1/Heating days (MON to SUN)

Day or days on which the switching times apply. Select the heating days with KEYS F1 (for Mon-day) to F7 (for Sunday). Pressing the button once → selects the day, pressing the button again → drops the day.

(04) Heating Period 1/Start (6:00)

Time to switch on air heater.

(05) Heating Period 1/End (22:00)

Time to switch off air heater.

(06-23) Heating Periods 2-7

These depend on the number of heating periods (see Mask 2), consisting of heating days, start and end.

(24) Temperature of return flow (60°C)

Desired temperature of return flow

(25) ECOcircuit (YES)

The ECO automatic savings system makes the air heater switch on and off as required.

(26) Switch off below system temperature (NO)

Should the air heater group be switched off when a minimum system temperature is fallen short of?

(27) Frost protection function (YES)

With the frost protection function switched on, the room heating unit is turned on when there is a danger of frost.

(28) Carry off excess heat (NO)

If the PYROT is at risk of overheating, there is the option of the excess heat being carried off. The group adjust to "Flow temperature/Maximum".

5.4.4 Annex buildings

Function (ECO-N):

The pipeline is usually supplied with a lowered temperature required by the weather-guided heating control system. The utility water heater is loaded at the maximum flow temperature set. To do so, the heating water is re-channelled by a valve to the utility water heater. The integrated timer shifts this to non-productive times, where the room heating unit is quickly interrupted.

Operating modes for the room heating unit

- **Off:**
The room heating system is switched off.
- **Day/Night:**
Heating operation according to clocked programme. Normal temperature during the day and reduced temperature at night.
- **Day/Off:**
Heating operation according to clocked programme. Normal temperature during the day and switched off at night.
- **Day:**
Normal temperature continuously.
- **Night:**
Reduced temperature continuously.
- **Manual:**
Pump on; the valve is not controlled (emergency operation).

(screen number) parameter (factory setting)

(01) Operating mode (Day/Night)

Select operating mode

(02) Number of heating periods (1)

The weekly programme has to be entered in the form of heating periods. Each weekly programme consists of the heating day, start and end. A maximum of seven heating periods is available.

(03) Heating Period 1/Heating days (MON to SUN)

Day or days on which the switching times apply. Select the heating days with KEYS F1 (for Mon-day) to F7 (for Sunday). Pressing the button once → selects the day, pressing the button again → drops the day.

(04) Heating Period 1/Start (6:00)

Time to switch from lowered temperature (or off) to normal temperature.

(05) Heating Period 1/End (22:00)

Time to switch from normal temperature to lowered temperature (or off).

(06-23) Heating Periods 2-7

These depend on the number of heating periods (see screen 2), consisting of heating days, start and end.

(24) Temperature of flow/at +5°C (43°C)

(25) Temperature of flow/at -15°C (64°C)

(26) Temperature Room Day (20°C)

Setting for temperature of room during daytime operation.

(27) Temperature Room Night (15°C)

Setting for temperature of room during nighttime operation.

(28) Night-time lowering of flow temperature by (-6°C)

This temperature set is subtracted from the flow temperature calculated for night-time lowering.

(29) Flow temperature; maximum (70°C)

The maximum limit for the flow temperature.

(30) ECOcircuit (YES)

The ECO automatic savings system makes the heating switch on and off as required.

(31) Switch off below system temperature (NO)

Should the room heating unit group be switched off when a minimum system temperature is fallen short of?

(32) Frost protection function (YES)

With the frost protection function switched on, the room heating unit is turned on when there is a danger of frost.

(33) Carry off excess heat (NO)

If the PYROT is at risk of overheating, there is the option of the excess heat being carried off. The room heating unit adjusts to "Flow temperature/Maximum".

The heating curve

See "Extended control system for room heating unit"

Room thermostat (ECO-ZR-QA):

See "Extended control system for room heating unit"

Operating modes of the utility water heater:

- **Off:**

The utility water heating system is switched off.

Timer:

Utility water heating following clocked programme.
(The boiler is only heated up during the heating period.)

- **On:**

The boiler is heated up when prompted for heat and when there is sufficient system temperature.

- **Manual:**

Pump on; the valve is not controlled (emergency operation).

Utility water heater (screen number) parameter (factory setting)

(34) Operating mode (timer)

Select operating mode

(35) Number of heating periods (1)

The weekly programme has to be entered in the form of heating periods. Each weekly programme consists of the heating day, start and end. A maximum of seven heating periods is available.

(Only with TIMER operating mode)

(36) Heating Period 1/Heating days (MON to SUN)

Day or days on which the switching times apply. Select the heating days with KEYS F1 (for Mon-day) to F7 (for Sunday). Pressing the button once → selects the day, pressing the button again → drops the day.

(37) Heating Period 1/Start (6:00)

Start, clearance, utility water heating.

(38) Heating Period 1/End (22:00)

End, clearance, utility water heating

(39-56) Heating Periods 2-7

These depend on the number of heating periods (see Mask 35), consisting of heating days, start and end.

(57) Temperature of utility water (60°C)

Set the desired temperature of the utility water.

5.4.5 Pipelining

Function (ECO-F):

This is for an annex building with a separate heat distribution system, which is supplied with heat via a pipeline. According to prompts by the heat distribution system, the temperature of the pipeline is pre-adjusted for the lowest loss in the line.

Operating modes:

- **Off**

Pump off; valve closed.

- **Automatic**

Adjustment to the temperature prompted.

- **Manual**

Pump on; the valve is not controlled (emergency operation).

(screen number) parameter (factory setting)

(01) Heating/Operating mode (Automatic)

Select operating mode

(02) Frost protection function (YES)

With the frost protection function switched on, the pipeline is turned on when there is a danger of frost.

(03) Flow temperature; minimum (20°C)

Minimum temperature desired

(04) Flow temperature; maximum (60°C)

Maximum temperature desired

5.4.4 Additional heat generator

Function (ECO-KP1):

The additional heat generator is automatically connected when required. This takes place after the system temperature is fallen short of that is set for covering the entire heat requirement or a peak in heat requirement. A boiler plant group is required to carry off heat for the additional boiler that will simultaneously provide for maintaining the return flow.

Operating modes:

- **Off:**
The additional heat generator is switched off.

- **Automatic:**
Automatic clearance of the additional heat generator when either an adjustable connecting temperature for the accumulator is fallen short of or a sensor for the forward flow bar.

- **On:**
Additional heat generator cleared.

- **Manual:**
Additional heat generator cleared and pump on; the valve is not controlled (emergency operation).

(screen number) parameter (factory setting)

(01) Operating mode (automatic)

Select operating mode

(02) Delay before connecting (15 min)

Clearance is given when the time set is up.

(03) Connecting temperature, system set-point temperature (-15°C)

If the system temperature falls by this amount below the system set-point temperature, the delay before connecting (screen 2) begins to lapse.

(04) Switch-off temperature for system set-point temperature (-5°C)

Switch-off difference in parallel operation

(07) Set-point temperature of return flow (50°C)

Desired temperature of return flow

(09) Load storage unit to (storage unit at top):

To which heat storage sensor should the storage unit be loaded?

(Indication only with accumulator option)

(10) Load storage unit to (70°C):

To what temperature on the accumulator sensor selected should the additional heat generator heat up the accumulator?

(Indication only with accumulator option)

(12) Service function of additional heat generator

A maintenance function for the specialist

(13) Operating hours counter

5.4.5 Solar

Function (ECO-S1):

This is used in simple solar systems with a single control circuit to heat the utility water in the solar utility water heater (Art. No: WSS-___). The ECO-S1 controller is an additional component for the ECO-B1(2) controller for the utility water heater. When the solar collector is hotter than the utility water at the bottom, it is heated up by the solar collector.

Operating modes

- **Off:**
Pump off; valve shut.
- **Automatic:**
Automatic heating of the solar utility water heater by means of difference-based control.
- **Manual:**
Emergency operation: Pump on.

(screen number) parameter (factory setting)

(01) Operating mode (automatic)

Select operating mode

(02) Temperature of utility water; maximum (65°C)

The maximum temperature of the utility water with solar heating.

(04) Collector/Utility water;

Set difference (10°C)

The difference between the solar collector and the utility water heater at the bottom

(10) Operating hours counter

Function (ECO-S3):

(Only possible with accumulator option)

This is used in large solar systems to heat the utility water in a solar utility water heater (Art. No: WSS-4050) and for supplying heat to the heat accumulator by means of a triple control circuit. The first circuit is for heating the domestic water, the second circuit is for heating the heat accumulator at the back/bottom and the third circuit is for heating the heat accumulator at the front/top. The heating storage unit is heated up by an externally situated plate-type heat exchanger. On switchover from utility water heater to heat accumulator, the secondary pump is switched on, which is then in operation with the solar pump. For optimised functioning, the flow rate in the secondary circuit has to be adapted to the primary circuit (e.g. with flow rate gauges in the primary and secondary circuits).

Operating modes

- **Off:**
Pump off; valve shut
- **Automatic:**
Automatic heating of the solar utility water heater and of the accumulator by means of difference-based control.
- **Manual:**
Emergency operation → Solar pump and secondary pump on; valves are not controlled (emergency operation).

(screen number) parameter (factory setting)

(01) Operating mode (automatic)

Select operating mode

(02) Temperature of utility water; maximum (65°C)

The maximum temperature of the utility water with solar heating.

(03) Priority to utility water (optimised)

- Optimised:

Priority to loading utility water, but if the solar output is not sufficient to finish loading the utility water heater, there is a switchover to solar heated heating. If the solar output rises (cyclical examination) so much that heating of utility water is possible, there is again a switchover to solar heated utility water.

- Absolute:

Loading utility water has absolute priority, i.e. solar heated heating is not allowed until the utility water heater has been completely loaded.

- No:

Solar heating of utility water/Heating according to the temperature difference between the collector and the utility water at the bottom or the collector and the storage unit at the bottom.

(04) Collector/Utility water; set difference (10°C)

The temperature difference between the collector and the utility water at the bottom for solar utility water heating.

(05) Collector/Storage unit; set difference (15°C)

The temperature difference between the collector and the storage unit at the bottom for solar heating system heating.

(10) Operating hours counter

6 Cleaning/Maintenance

6.1 Boiler

The heat exchanger, flue pipe, and chimney must be cleaned regularly to remove accumulated creosote and ash. Ensure that the heating exchanger, flue pipe, and chimney are cleaned at the end of the heating season to minimize corrosion during the summer months. The appliance, flue pipe, and chimney must be in good condition.

Regular cleaning and maintenance of the boiler system is the customer's most important job for years of trouble-free operation and to obtain the greatest possible output with the best efficiency.

Here the cleaning intervals for chip material are listed with clinging bark – 0.8% ash content. The cleaning intervals may vary, depending on the fuel, the amount of fine matter and the operating method.

CAUTION – RISK OF INJURY: Before beginning cleaning work, put the facility out of operation. Be absolutely sure to wear protective gloves, protective eyewear if required and use the cleaning utensils that come with the facility (danger of blow-ups, burns and getting crushed)!

With pneumatic pipe cleaning system, after approx. 600 operating hours; without pneumatic pipe cleaning system, after approx. 300 operating hours:

Open boiler door and clean all the heat exchanger pipes (9) with wire cleaning brush. Use the stoker to carefully draw to the front the fly ash lying in the rotation combustion chamber (8).

IMPORTANT:

With pneumatic pipe-cleaning system, disconnect the compressed air line before opening the boiler door – danger of injury!

After approx. 1000 operating hours:

Unplug the plug from the exhaust gas fan, unscrew butterfly nuts, pull out motor with impeller and clean with broom or wire brush.

CAUTION: DANGER OF INJURY – be absolutely sure to switch off master switch.

After approx. 300 operating hours:

Open lid across from feed auger and clear the slots in the grate (5).

After approx. 300 operating hours:

Take off and clean light barriers and inspection windows on the firing block. Remove dust and ash deposits in the openings.

After approx. 100 operating hours:

Open ash pan doors and empty ash containers.

With automatic de-ashing (optional), cleaning interval of approx. 1000 operating hours

After approx. 1000 operating hours:

Clean recirculated flue gas line.

After approx. 300 operating hours:

Remove ash from the exhaust gas collector.

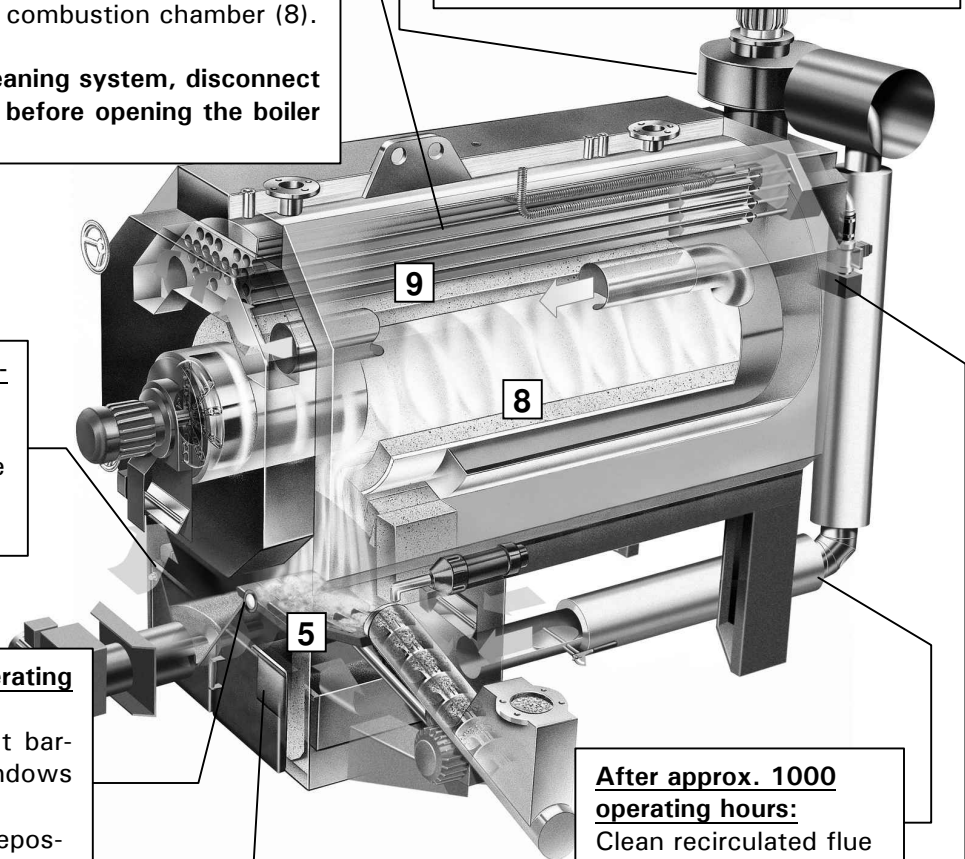

Exhaust gas deduster, detached (optional)

After approx. 1000 operating hours:

Unplug the plug, unscrew butterfly nuts, pull out motor with impeller and clean with broom or wire brush.

CAUTION: DANGER OF INJURY – be absolutely sure to switch off master switch.

After each cleaning of the set of tubing

Open lid and clean the guide blades of the de-duster with hand-brush.

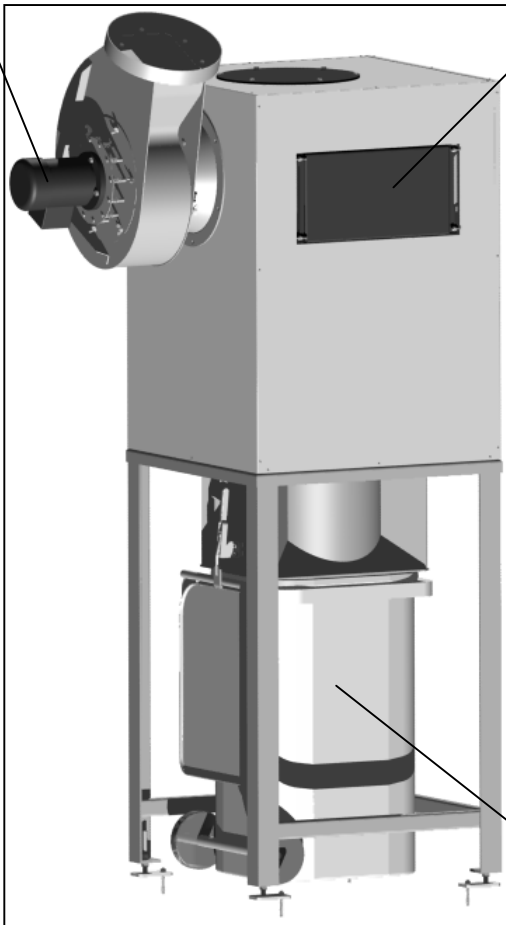

After approx. 300 operating hours (90-litre ash bin):

Empty ash bin beneath the de-duster.

Pneumatic tube-cleaning system (optional)

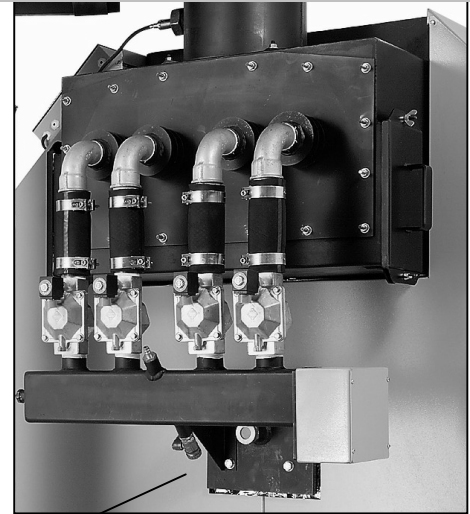

Regularly drain condensation water in the compressed air distribution bar.

- Operation and maintenance of the compressor (optional) according to the manual that comes with the facility.
- The timer that comes with the compressor is for limiting the running time and should be mounted between the compressor and the power supply.
- When the compressed air system is provided by the customer, the compressor has to be suited for continuous operation or be secured against continuous operation (e.g. timer for limiting running time).
- Continuous operation of the compressor indicates leakage in the air system. Check air supply line and valves for leakage.

IMPORTANT: Never operate the boiler without ash container!

6.2 Installing the displacement rods into the heat exchanger

The displacement rods improve the heat transmission in the heat exchanger and reduce the temperature of the exhaust gas, thus improving the efficiency of the heating system. They are taken out to clean the heat exchanger tubes and then put back in.

Insert the displacement rods into the heat exchanger tube with the thick end first. Push until they are flush with the bottom of the tube. Tolerance ± 5 mm.

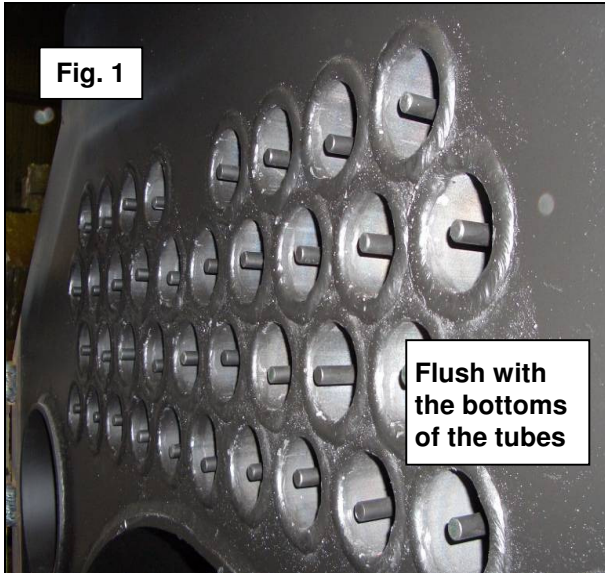

Remove the displacement rods with a pair of pliers, as shown below. The heat exchanger should be cleaned at the intervals prescribed so that, on the one hand, performance and efficiency are maintained, and on the other, the displacement rods can be easily removed.

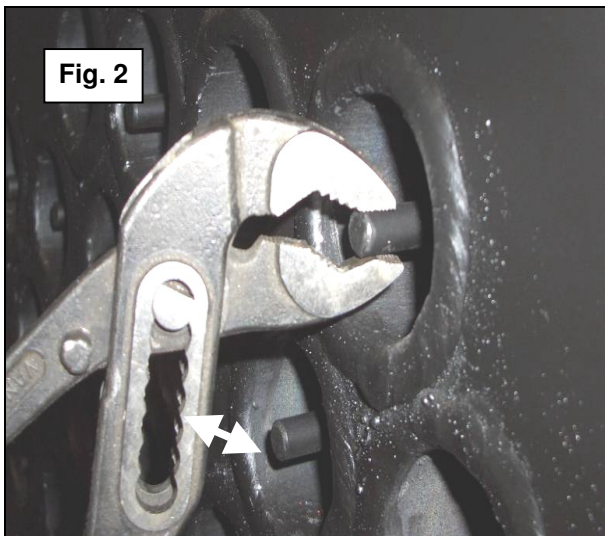

6.3 Feed systems

When storage facilities for wood are required the wood should be kept at least 1.5m (5ft) from the heating appliance.

All the geared motors on the feed systems are maintenance-free.

- A change of lubricant and/or oil is recommended every 20,000 operating hours or every three years.
- Re-lubricate flange bearings and other lubricating points regularly with lithium soap grease.
- Check chain drives for wear and, if necessary, tighten them up and lubricate with chain oil.
- Check all the bolts to be sure they are snug.
- Once a year check the extraction components in the silo and/or bunker for damage and soiling. Remove any foreign matter there might be.
- Rotary sweep extraction system (AG)
- Check and lubricate elbow joints, pivot pins, tension springs and tension chains. Readjust elbow joints if necessary.
- Inclined extraction system (AP/APS)
- Lubricate the gasket between the extraction casing and the geared motor and universal joint for the auger.

If fuel hopper is installed, do not alter equipment in any way.

May be connected to an existing boiler or solar system.

IMPORTANT: Never use inflammable lubricants!

7 Shutdown

Heating boiler

- Pipe-type heat exchanger:
When the PYROT is put out of operation for a long period (such as for summer breaks), be sure to carefully clean the pipe-type heat exchanger with a steel brush required.
- Prevent high-temperature corrosion when chipboards are incinerated:
If the heating room is moist or there is any other atmosphere that promotes corrosion (e.g. poor ventilation, residual enamel near the heating room, etc.), after carrying out the cleaning, also spray the pipe-type heat exchanger with biodiesel.
- If there is a danger of frost, empty the heating system, following the heating installer's rules, or have anti-frost agent filled.

Control system

Even when the PYROT is put out of operation for long periods, the power supply to the control system should not be interrupted (do not turn off master switch).

Why?

- The "intermittent control system" switches the consumer pumps on for five seconds every 24 hours. This prevents the pumps from jamming during long standstills. This saves on expensive repairs.
- Prevent the formation of condensation in the lambda sensor.
- Extend the service life of the buffer battery.

8 Carrying out disposals

Shutdown

- If necessary, first switch off the PYROT using the F1 or F2 key. When the burn-out has taken place, and the burner has cooled off, turn off the master switch.
- Disconnect the mains connection to the control cabinet.

CAUTION DANGEROUS VOLTAGE!

Only licensed electrical firms are allowed to disconnect and dismantle the connection to the electrical network.

- Close the forward flow and return flow slide valves.
- Open the drain tap on the bottom of the boiler of the PYROT and drain water.

Only heating system installers may drain the boiler and dismantle the connections to the heating system.

- Disconnect the forward flow pipe and return flow pipe from the PYROT.

Instructions regarding transport to a different location

The personnel who carry out transports to different locations have to know the dangers involved of accidents that might arise in doing so and use suitable measures to prevent such from happening.

Instructions regarding waste disposal

- Ashes should be stored in covered metal container on non-combustible floors away from combustible material
- Comply with customary laws and regulations on disposing of waste.
- Contract a disposal firm to dispose of and recycle waste in an environmentally friendly fashion.

A prerequisite for approval is the express permission for such by the public authority responsible. For claims to the warranty according to Section 11 of our General Terms and Conditions of Delivery, wood fuels have to meet the following conditions. If those conditions are not met, then approval is possible with restrictions (warranty, maintenance, operational safety) with a written statement by the manufacturer in reference to the facility.

1) Non-combustible substances contained

No wood fuels may contain any foreign bodies, such as pieces of metal, stones, masonry remnants or plastics. Nor must the following limits (per kg of dry fuel) for non-combustible substances contained (ash analyzed at a temperature of 815°C) be exceeded or fallen short of:

	Limit	Comparison with untreated forest wood
1.1) Chlorine Cl:	max. 300 mg/kg	10 mg/kg
1.2) Sulphur S:	max. 1000 mg/kg	120 mg/kg
1.3) Total Cl, S:	max. 1000 mg/kg	130 mg/kg
1.4) Ash content, total:	max. 15.0 g/kg	5.0 g/kg
1.5) Alkali oxides in the ash (K ₂ O and Na ₂ O):	max. 1.0 g/kg	0.35 g/kg
1.6) Sintering point of the ash:	min. 1000°C approx. 1200°C	

Consequence of substantial overstepping of limits (1.1, 1.2, 1.3, 1.5, 1.6):

- a) Hot-gas corrosion in the heat exchanger → Special maintenance instructions for heat exchanger
→ Shortened service life of heat exchanger
- b) Early sintering and melting of the ash → Special maintenance instructions for firing,
→ Increased maintenance costs (firing, boiler door)

If the maintenance instructions are not followed, a process will be created that builds up in a negative fashion with:

→ Cinders change the airflow → Temperature peaks → more slag → etc, until there is fast destruction of the refractory materials

1.7) Additives in remnant and used wood: Free of heavy metals and halogen compound

2) Superfine & dust (wood particles smaller than 1.0 mm)

2.1) Without pre-dryer, max. 10.0% of the total mass; consequence of substantial overstepping of limit:

Temperature peaks → Slag formation → Even higher temperature → etc, to the point of destruction;

→ Special maintenance instructions for firing;

Elevated values are especially critical for remnant wood in combination with elevated values as per 1.1, 1.2

2.2) For forest wood chips with pre-dryer, max 4.0% of the total mass; consequence of substantial overstepping of limit:

→ Moving the exhaust air lines → Special maintenance instructions for cleaning exhaust air line

3) Origin and treatment

3.1) Forest wood and plantation wood (complete trees and trunk wood untreated)

Mature wood from trunks and branches, untreated, chopped as billet wood or chips

3.2) Compressed wood, pellets

Untreated wood with limited bark content, compressed by machine and calibrated

3.2) Increased proportion of bark, tree cuttings from roadside trees (untreated)

Remnants from the forestry and sawmill industries or from conservation of the countryside (elevated ash content).

3.3) Remnants from derived timber products

Usually a mixture of untreated and treated wood in the form of shavings from processing machinery and chips from choppers that run slowly. In cases of elevated proportions of dust and/or limited storage volumes, these shavings are compressed into briquettes.

3.4) Used wood

This is essentially untreated wood that has been used prior to its energetic utilization (e.g. pallets). It is reduced in size by shredders for thermal utilization. The metal parts have to be removed afterwards (by magnetic separators).

4) Particle size: adjustment of the conveyor augers

4.1) G30/G50 chips from untreated wood:

made by fast-running and cutting tools;

	max. coarse fraction	with cross-section	and length
G 30	of 20% max.	3 cm ²	max. 8.5 cm;
G 50	of 20% max.	5 cm ²	max. 12 cm;

Required cross-sections of the loading: depends on the boiler output:

		up to 150 kW	up to 500 kW	from 500 kW
Conveyor auger	D	min. 12 cm;	min. 15 cm;	min. 20 cm
Drop cross-section	A	min. 175 cm ²	min. 300 cm ²	min. 600 cm ²

4.2) Chips not from the forest; origin as per 3.2, 3.3, 3.4; briquettes, origin as per 3.3

Size essentially as per ÖNORM M 7133 G50, additionally, however:

- Fraction of one-offs max. 5% with cross-section of max. 5 cm² up to a length of max. 16 cm
- Frayed surface by chopping tools (shredders) or slow-running choppers
- Briquettes, diameter max. D 60 mm (hydraulic compressors, pressure geared to loading system)
- Conveyor augers diameter min. 20 cm; drop-off route, rotary valve cross-section min. 600 cm²
- Consequence of overstepping particle size:
 - Extra expenditures for correcting malfunctions
 - Shortened service life of the conveyor augers and drives

5) Bulk density **S** (kg/m³), water content **W** (%), size **G** (mm)

Bulk density **S** in kg/m³ (lb/ft³), water content **W** in %, size C1, C3, C4, C5, P1, P2, P3 as per CAN/CSA-B366.1-M91

In biomass boiler plants, the wood fuels that will be used are to be individually listed as follows:

- a) S 130 (8.1) W10 to W20 C1 Sawdust, untreated (planing shop)
- b1) S 200 (12.5) W20 to W35 C1 Sawdust, untreated (sawmill)
- b2) S 200 (12.5) W20 C3, C4, C5 Forest wood chips, soft, untreated
- c1) S 250 (15.6) W20 to W35 C3, C4, C5 Forest wood chips, soft, untreated
- c2) S 250 (15.6) W35 to W50 C1 Sawdust, untreated (sawmill)
- d1) S 300 (18.7) W20 to W35 C3, C4, C5 Forest wood chips, soft/hard, untreated
- d2) S 300 (18.7) W35 to W50 C3, C4, C5 Forest wood chips, soft, untreated
- e1) S 350 (21.8) W20 to W35 C3, C4, C5 Forest wood chips, hard, untreated
- e2) S 350 (21.8) W35 to W50 C3, C4, C5 Forest wood chips, soft/hard, untreated
- e3) S 350 (21.8) W50 to W60 C3, C4, C5 Forest wood chips, soft, untreated
- f1) S 400 (24.9) W35 to W50 C3, C4, C5 Forest wood chips, hard, untreated
- f2) S 400 (24.9) W50 to W60 C3, C4, C5 Forest wood chips, soft/hard, untreated
- g) S 130 (8.1) less than W15 C3, C4, C5 Shavings & chips from wood remnants, dry, mixed
- h) S 200 (12.5) less than W15 C3, C4, C5 Shavings & chips from wood remnants, dry, mixed
- i) S 250 (15.6) less than W15 C3, C4, C5 Shavings & chips from wood remnants, dry, mixed
- j) S 350 (21.8) less than W15 P3 Briquettes from wood remnants 20mm (3/4 in) to max. 60 mm (2 in)
- k1) S 650 (40.6) less than W10 Pellets P1 conforming to standards, untreated up to 10 mm (3/8 in)
- k2) S 650 less than W10 Pellets P2 conforming to standards, untreated D 11 (3/8 in) to 20 mm (3/4 in)

6) Maximum water content allowed, **W**, (percentage by weight of the total mass)

The maximum water content allowed in the fuel when entering the furnace should be taken from the spec sheets for the furnace series. With a pre-dryer installed between the furnace and the fuel storage site, extra water content can be in the fuel stored (see specifications in reference to the order). The water content influences the maximum furnace output possible, the heat emission required to the pre-dryer and thus the maximum heat emission possible to the consumers.

7) Other information

7.1) Ash and cleaning

Untreated wood without bark has a proportion of ash less than 0.5% of the fuel mass supplied. All the specifications regarding cleaning involved are based on untreated wood with bark attached with an ash amount of 0.8%. The cleaning and maintenance involved for other wood fuels should be adapted according to the amount, the specific weight and the behavior of the ash.

7.2) Changing fuels

A great change in fuel quality, such as bulk density, water content, dust proportion or ash content might make a manual correction of the firing parameters necessary (see Operating Manual).

8) Non-woody fuels from biomass

Non-woody fuels from biomass, such as needles, foliage, grain, straw, fruit pits, etc, are usually unsuited as fuel for trouble-free operation and thus are not approved.

9) Information documented

The installation instructions contain the information required according to the subject boilers have been tested and examined in accordance with:

CSA B366.1-M91
Solid Fuel Fired Central Heating Appliances

CSA C.22.2#3-M88(R2004)
Electrical Features of Fuel Burning Equipment

UL391 (4thEd)
Solid Fuel and Combination-Fuel Central and Supplementary Furnaces
CSA B365-01
Installation Code for Solid Fuel Burning Appliances and Equipment

Malfunction report / malfunction remedy

<u>Heat Generation</u>				
No.	Text displayed for malfunction	Malfunction alarm	Possible cause	Check / Remedy
01	Excess temperature (F1, F2, F3 lights up red)	- Temperature-limiting safety switch N21 (TLSS) up at the burner.	- In correct setting on the control module - Defective component (pump or valve) - Sudden drop in output to zero. The feed auger then has to be run to zero. The heat then produced by this can result in excess temperature. Activate the function "Dissipate excess heat".	- Why could the heat not be dissipated? - Check the burner circuit pump and modulating valve. - Activate the function "Dissipate excess heat". - On the TLSS, screw off the protective cap and press the reset button (not possible until the burner temperature is less than 70 °C) and press OK.
03-17	Interruption or short-circuit, sensor (F3 lights up red)	- Sensor . . .	- Damage to the sensor connecting line - Malfunction alarm defective	- Call in electrician
09	Lambda sensor (F3 lights up red)	- Lambda sensor on the back of the burner	- Malfunction alarm very soiled - Malfunction alarm defective - Error in the electronics	- Readjust lambda sensor - Acknowledge with OK
18	Permanent code (F3 lights up red)	- Operating hours lapsed before the permanent code has been entered.	- Permanent code has not been entered	- Call burner supplier
19	Repeat heating up (F3 lights up red)	- Exhaust gas sensor - Lambda sensor	- Fuel too moist - Lambda sensor imprecise - Ignition device defective - The combustion chamber filling time is too short	- Use suitable, dry fuel. - Readjust lambda sensor. - Replace ignition device. - Readjust combustion chamber. - Acknowledge with OK
20	Water level in extinguishing water container (F3 lights up red)	- Level float switch in extinguishing water container	- Too little water in the extinguishing water container.	- Fill extinguishing water container - Acknowledge with OK
25	Light barrier, ember monitoring system (F3 lights up red)	- Light barrier for ember monitoring system	- Viewing windows soiled; deposits of ash in the openings - Defective malfunction alarm.	- Remove and clean viewing windows on both sides. Remove dust and deposits of ash from the openings. Refer to the Operating and Maintenance Instructions, "Cleaning" section - Acknowledge with OK
26	Light barrier, feed auger (F3 lights up red)	- Light barrier in the metering container for the feed auger	- Light barrier soiled - Clogging in the metering container	- Clean light barrier - Undo clogging - Acknowledge with OK
96	Feed auger pipe too hot	- Temperature sensor on the feed auger	- Power failure - Consequent malfunction caused by excess temperature - Light barriers for ember monitoring system soiled	- Call in electrician - Check light barriers for embers. - Acknowledge with OK
81-93	BUS error, no connection to the . . . (F3 lights up red)	- Data transmission line for the bus connection	- Bus connection interrupted	- Check plug connections - Replace data transmission line - Call supplier
53-54	Extraction system ... silo door open (F4 lights up red)	- Limit switch for silo door	- Silo door open	- Check and close silo door. - Acknowledge with OK.

Malfunction report / malfunction remedy

Loader System				
No.	Text displayed for malfunction	Malfunction alarm	Possible cause	Check / Remedy
01	Material shortage (F4 lights up red)	- Light barrier in the metering container - Light barriers for the ember monitoring system	- Silo is empty - Material clogged	- Fill silo - Switch off master switch and undo material clogging - Acknowledge with OK
11-24	Starttec ... (F4 lights up red)	- Starttec (motor starter mounted on clipboard for the motor) - Red lamp on the Starttec lights up	- Phase sequence mixed up - Motor overloaded - Other causes, depending on the malfunction displayed.	- Correct the phase sequence (clockwise rotating magnetic field) - Undo clogging; make motor smooth-running - Refer to documentation for Starttec - Acknowledge with OK
30	Feed auger (F4 lights up red)	- Reversed control of feed auger	- Material clogging in the feed auger	- Undo material clogging
31-45	Conveyor device ... (F4 lights up red)	- Maintenance cover limit switch	- One of the maintenance covers is open or not closed properly.	- Check and close all the maintenance covers. - Acknowledge with OK
51-52	Extraction system ... (F4 lights up red)	- Maintenance cover limit switch	- One of the maintenance covers is open or not closed properly.	- Check and close all the maintenance covers. - Acknowledge with OK
53-54	Extraction system ... Hydraulic drive, temperature/level (F4 lights up red)	- Level float switch in the oil container for the sliding bar extraction system - Thermostat in the oil container	- Oil level too low, (possible loss of oil) - Oil has been overheated by too high pressure.	- Refill oil. Check oil line for leakage - Check and adjust operating pressure (by KÖB) - Acknowledge with OK.
53-54	Extraction system ... silo door open (F4 lights up red)	- Limit switch for silo door	- Silo door open	- Check and close silo door. - Acknowledge with OK.
No.	Text displayed for malfunction	Malfunction alarm	Possible cause	Check / Remedy
01-27	Interruption or short-circuit, sensor ... (F... lights up red)	- Sensor ...	- Damage to the sensor connecting line - Malfunction alarm defective	- Call in electrician

Quick Reference

°C	°F
-40	-40
-35	-31
-25	-13
-20	-4
-18	0
-16	+3
-14	+7
-12	+10
-10	+14
-9	+16
-8	+18
-7	+19
-6	+21
-5	+23
-4	+25
-3	+27
-2	+28
-1	+30
0	+32
+1	+34
+2	+36
+3	+37
+4	+39
+5	+41
+6	+43
+7	+45
+8	+46
+9	+48
+10	+50
+12	+54
+14	+57
+16	+61
+18	+64
+20	+68
+25	+77
+30	+86
+35	+95
+40	+104
+50	+122
+60	+140
+70	+158
+80	+176
+90	+194
+100	+212
+110	+230

Viessmann Manufacturing Company Inc.
750 McMurray Road
Waterloo, Ontario N2V 2G5 Canada
Tel. (519) 885-6300 Fax (519) 885-0887
www.viessmann.ca info@viessmann.ca

Viessmann Manufacturing Company (U.S.) Inc.
45 Access Road
Warwick, Rhode Island 02886 USA
Tel. (401) 732-0667 Fax (401) 732-0590
www.viessmann-us.com info@viessmann-us.com