

# Vitocontrol-C, Ecotronic KRT 150-300

PN: 7411902

Project : Oakland University

Project No. : PRJ-00240

### Technical data

Power supply : 208V, 60Hz, 3ph L1,L2,L3/N/G

Main fuse : 45A

Dimensions : 1000 x 1200 x 300 mm

Degree of protection : IP65, NEMA type 4

### Preliminary remarks:

Retighten all wire holding screws inside the control before start-up.

Provide fuseable disconnect means according to local code.

Field modifications of control manufactured by K-W Electronic Service Inc. and / or Viessmann Mfg. Inc. will void factory CSA certification! If modifications are performed, electrical safety field inspection is required according to local codes. K-W Electronic Service Inc. and Viessmann Manufacturing Company Inc. are not responsible for any damage, injury or loss of life resulting from field modifications.

## Attention:

This is not complete system drawing. The installer has the responsibility to assure that the control is suitable for the respective installation, and all necessary safety equipment is installed.

## Attention:

The information about wire type, wire number and wire gauge, made in the wiring diagrams is not obligatory. The final decision of these settings has to be done by the executing installation company considering the local codes and regulations.

Prepared : 11.09.15 by PD  
Control approved : - by -

Number of pages: 41



LR 102874

# Table of contents

F06\_003

Page	Page type	Page description	Date	Revision
1	Title page / cover sheet	Title page		
2	Table of contents	Table of contents : 1 - 101	11.09.15	12.01.12
2.1	Table of contents	Table of contents : 102 - 103	12.01.12	
3	Parts list	Parts list : IDE.PS 24= 120W - KOB.Ecotronic BMK1600.1D	11.09.15	12.01.12
4	Panel layout	Panel layout	11.09.15	12.01.12
5	Schematic multi-line	Power	11.09.15	
6	Schematic multi-line	KSK and ZPK supply system	11.09.15	
7	Schematic multi-line	Safety chain evaluation	11.04.01	12.01.12
8	Schematic multi-line	De-ashing auger M4 De-ashing ascending conveyor auger M5	11.09.15	
9	Schematic multi-line	Boiler pump	11.09.15	
10	Schematic multi-line	Error report	11.09.15	
11	Schematic multi-line	Loader module M31 External loader system T32	11.09.15	12.01.12
12	Schematic multi-line	Spring-operated extraction system T32	12.01.12	
14	Schematic multi-line	Exhaust fan	11.09.15	
15	Schematic multi-line	CAN plug	11.09.15	
16	Schematic multi-line	Light barrier- embers 1 B1	11.09.15	
17	Schematic multi-line	Light barrier- embers 2 B2	11.09.15	
18	Schematic multi-line	Light barrier- de-ashing system B4	11.09.15	
19	Schematic multi-line	Water level safety switch N1	11.09.15	
20	Schematic multi-line	Secondary airflow valve M13	11.09.15	
21	Schematic multi-line	Primary airflow valve M10	11.09.15	
22	Schematic multi-line	Sensors	11.09.15	
23	Schematic multi-line	Lambda sensor B26 Slide valve T30	11.09.15	
24	Schematic multi-line	Ignition blower	11.09.15	
25	Schematic multi-line	Spare output	11.09.15	
26	Schematic multi-line	Boiler valve	11.09.15	
27	Schematic multi-line	Grate drive M2	11.09.15	
28	Schematic multi-line	Rotation blower M3	11.09.15	
29	Schematic multi-line	Solenoid valves (pneumatic cleaning system)	11.09.15	
30	Schematic multi-line	Combustion chamber door safety	11.09.15	
50	Cable overview	Cable overview : 5W1 - 29W1	11.09.15	12.01.12
50.1	Cable overview	Cable overview : 29W1 - 29W1	12.01.12	
59	Terminal diagram	Terminal diagram : X1	11.09.15	12.01.12
59.1	Terminal diagram	Terminal diagram : X1	11.09.15	12.01.12
60	Terminal diagram	Terminal diagram : X2	11.09.15	12.01.12
60.1	Terminal diagram	Terminal diagram : X2	12.01.12	
61	Terminal diagram	Terminal diagram : X3	11.09.15	12.01.12
100	Graphic	Schematic diagram	11.09.15	
101	Graphic	Arrangement of electrical wiring	11.09.15	

Previous page: 1

Next page: 2.1

2		
1		12.01.12
Rev.	Description	Date
		Date: 11.09.15



Viessmann Manufacturing  
Company Inc.  
750 McMurray Road,  
Waterloo, Ontario N2V 2G5

Project name: Oakland University

Page title: Table of contents : 1 - 101

Project No.:  
**PRJ-00240**

Page: 2 of: 103



# Parts list

VI\_F01\_001

Device tag	Quantity	Designation	Type / Model	Producer	Order No.
-4A1	1	Power supply 24 VDC 120W	P55R-SF24	Idec	267046
-11D1	1	Diode 400V 1A	1N4004-T	Diode Inc.	266041
-12D2	1	Diode 400V 1A	1N4004-T	Diode Inc.	266041
-5F1	3	Fuse 45A/600V class J	AJT45	Ferraz	255040
-6F1	1	Fuse 6.25A/250V time delay	GDL6-1/4	Ferraz	255010
-6F10	1	Circuit breaker 2 pole 13A	91H22-13 (9929830000)	Weidmüller	262042
-8F4	1	Motor circuit controller 1.6-2.5A	KTA7-25S-2.5A	Sprecher & Schuh	261039
-8F4	1	Auxiliary contact NO	KT7-PE1-10	Sprecher & Schuh	261046
-8F4	1	Terminal adapter	KT7-250TE1	Sprecher & Schuh	261064
-8F5	1	Motor circuit controller 2.5-4A	KTA7-25S-4A	Sprecher & Schuh	261040
-8F5	1	Auxiliary contact NO	KT7-PE1-10	Sprecher & Schuh	261046
-8F5	1	Terminal adapter	KT7-250TE1	Sprecher & Schuh	261064
-9F20	1	Motor circuit controller 1-1.6A	KTA7-25S-1.6A	Sprecher & Schuh	261038
-9F20	1	Auxiliary contact NO	KT7-PE1-10	Sprecher & Schuh	261046
-9F20	1	Terminal adapter	KT7-250TE1	Sprecher & Schuh	261064
-11F1	1	Circuit breaker 3-pole 10A	91H32-10 (9925890000)	Weidmüller	262053
-12F1	1	Circuit breaker 3-pole 10A	91H32-10 (9925890000)	Weidmüller	262053
-14F11	1	Circuit breaker 2 pole 20A	91H22-20 (9925570000)	Weidmüller	262044
-24F1	1	Fuse 0.5A/250V time delay	GDL1/2	Ferraz	255014
-26F1	1	Fuse 0.25A/250V time delay	GDL1/4	Ferraz	255054
-14FU	1	Variable frequency drive 0.75kW 240V	E82EV751K2C	LENZE	9619353
-14FU	1	Function module	E82ZAFCC001	LENZE	9619357
-5H1	1	Panel light 24 VDC, 3.5W	LF1B-C4S-2THWW4	Idec	203200
-6K11	1	Contactactor 18A 240VAC	CGC-18A-240	Carlo Gavazzi	260053
-6K12	1	Relay DPDT 120VAC	RJ2S-C-A120	Idec	250106
-7K1	1	Contactactor 12A 24VDC	CGMS-12D-24S-01	Carlo Gavazzi	260050
-7K2	1	Contactactor 12A 24VDC	CGMS-12D-24S-01	Carlo Gavazzi	260050
-8K4	1	Contactactor 12A 120VAC	CGMS-12A-120-10	Carlo Gavazzi	260035
-8K5	1	Contactactor 12A 120VAC	CGMS-12A-120-10	Carlo Gavazzi	260035
-9K20	1	Contactactor 12A 240VAC	CGMS-12A-240	Carlo Gavazzi	260054
-10K0	1	Relay SPDT 120VAC	RJ1S-C-A120	Idec	250103
-24K1	1	Contactactor 18A 120VAC	CGC-18A-120	Carlo Gavazzi	260037
-24K2	1	Contactactor 18A 120VAC	CGC-18A-120	Carlo Gavazzi	260037
-26K1	1	Relay SPDT 120VAC	RJ1S-C-A120	Idec	250103
-26K2	1	Relay SPDT 120VAC	RJ1S-C-A120	Idec	250103
-28K1	1	Contactactor 12A 120VAC	CGMS-12A-120-10	Carlo Gavazzi	260035
-5Q1	1	Disconnect 3-pole 60A	KG 64B	K&N	263061
-28Q1	1	Motor circuit controller 1-1.6A	KTA7-25S-1.6A	Sprecher & Schuh	261038
-28Q1	1	Terminal adapter	KT7-250TE1	Sprecher & Schuh	261064
-11R1	1	Resistor 120 ohm 0.25W	ERD-S2TJ120V	Panasonic	258116
-5S1	1	Door switch	4127000	RITTAL	263065
-15T1	1	Transformer 230-12.5/18V 2A	NTK2C (0396010515)	Schnidbauer	7164066
-26T1	1	Transformer 120-24V 20VA class 2	S82A-310	White Rodgers	254011
-6U1	1	Main board	KSK	Köb	7393633
-6U2	1	Slave board	ZPK	Köb	9622452
-11U31	1	Soft starter	E71MM402-2A010	LENZE	9619402
-11U31	1	Function module	E82ZAFCC001	LENZE	9619357
-12U32	1	Soft starter	E71MM402-2A010	LENZE	9619402
-12U32	1	Function module	E82ZAFCC001	LENZE	9619357
-15U1	1	Control module	BMK1600.1D	Köb	7161567

Previous page: 2.1

Next page: 4

2			 Viessmann Manufacturing Company Inc. 750 McMurray Road, Waterloo, Ontario N2V 2G5	Project name: Oakland University  Page title: Parts list : IDE.PS 24= 120W - KOB.Ecotronic BMK1600.1D	Project No.:
1		12.01.12			PRJ-00240
Rev.	Description	Date:			Page: 3 of: 103

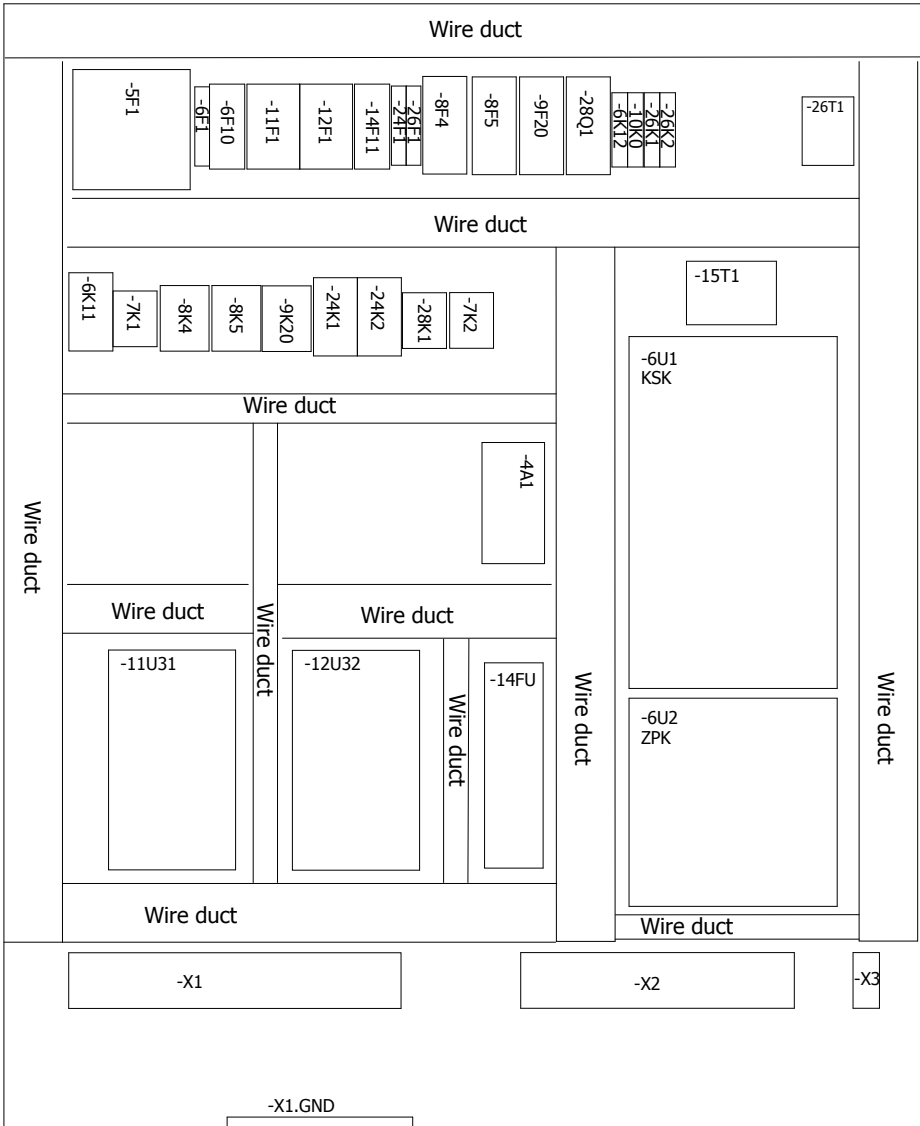

2		
1	Components changed	12.01.12
Rev.	Description	Date
		Date: 11.09.15



Viessmann Manufacturing Company Inc.  
750 McMurray Road,  
Waterloo, Ontario N2V 2G5

Project name:	Oakland University
Page title:	Panel layout

Project No.:	PRJ-00240
Page:	4 of: 103

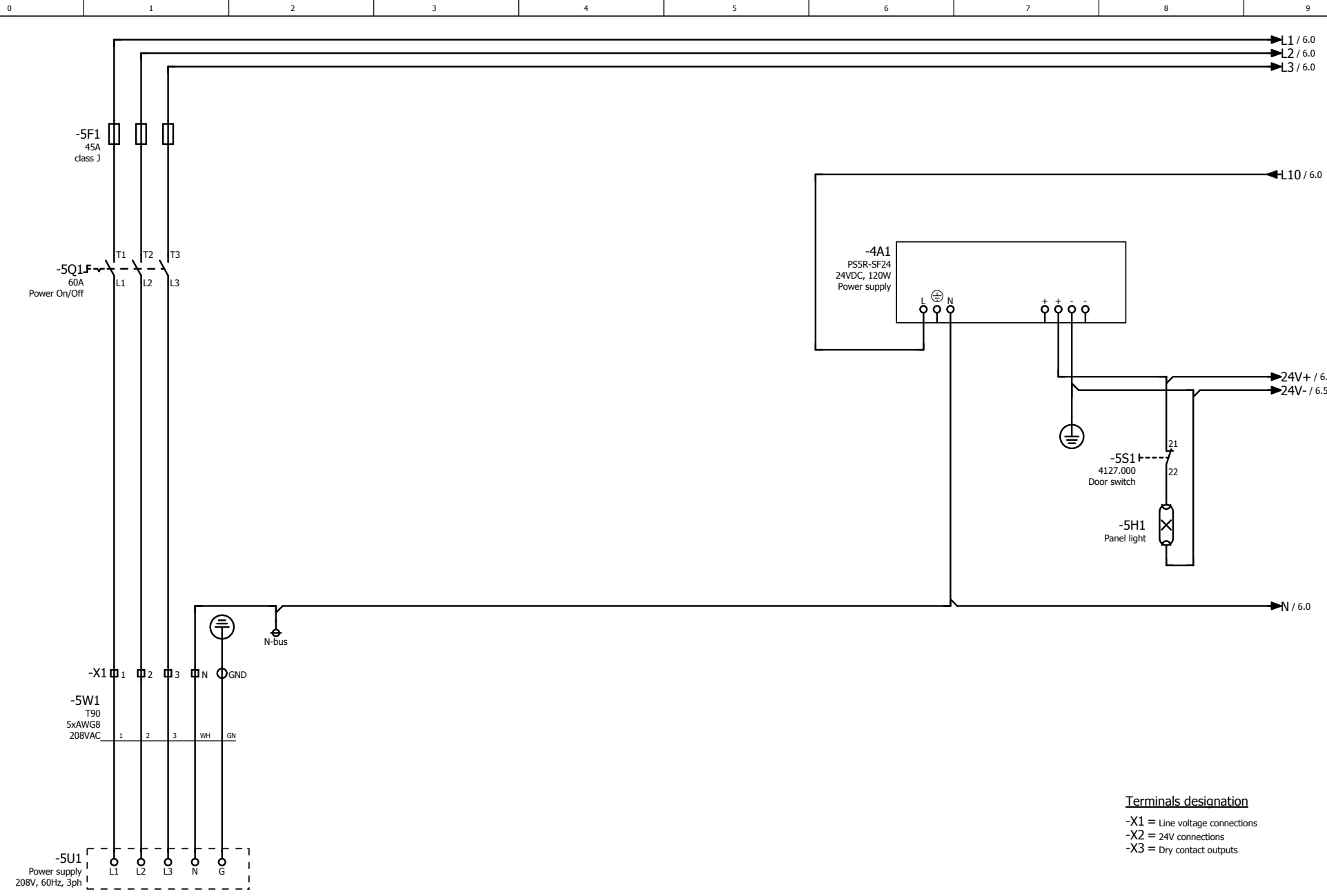

Internal factory wiring. ▲ Field connections. ▼

**Terminals designation**  
 -X1 = Line voltage connections  
 -X2 = 24V connections  
 -X3 = Dry contact outputs

Previous page: 4

Next page: 6

2		
1		
Rev.	Description	Date
		Date: 11.09.15

**VIESSMANN**  
 Viessmann Manufacturing Company Inc.  
 750 McMurray Road,  
 Waterloo, Ontario N2V 2G5

Project name: Oakland University  
 Page title: Power

Project No.: PRJ-00240  
 Page: 5 of: 103

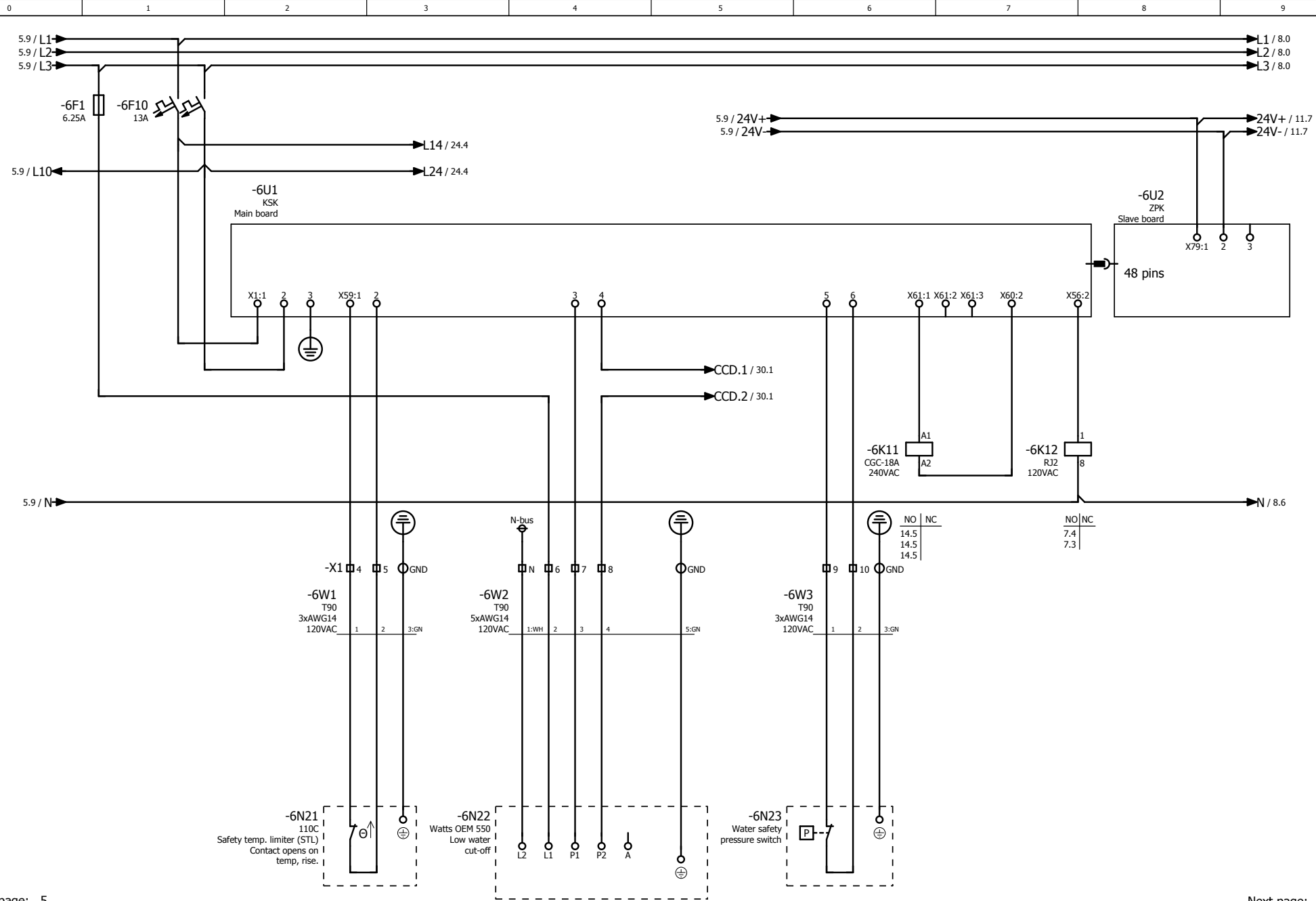

Internal factory wiring. ▲ Field connections. ▼

Previous page: 5

Next page: 7

2		
1		
Rev.	Description	Date
		Date: 11.09.15



Viessmann Manufacturing Company Inc.  
750 McMurray Road,  
Waterloo, Ontario N2V 2G5

Project name: Oakland University  
Page title: KSK and ZPK supply system

Project No.:	PRJ-00240
Page: 6	of: 103

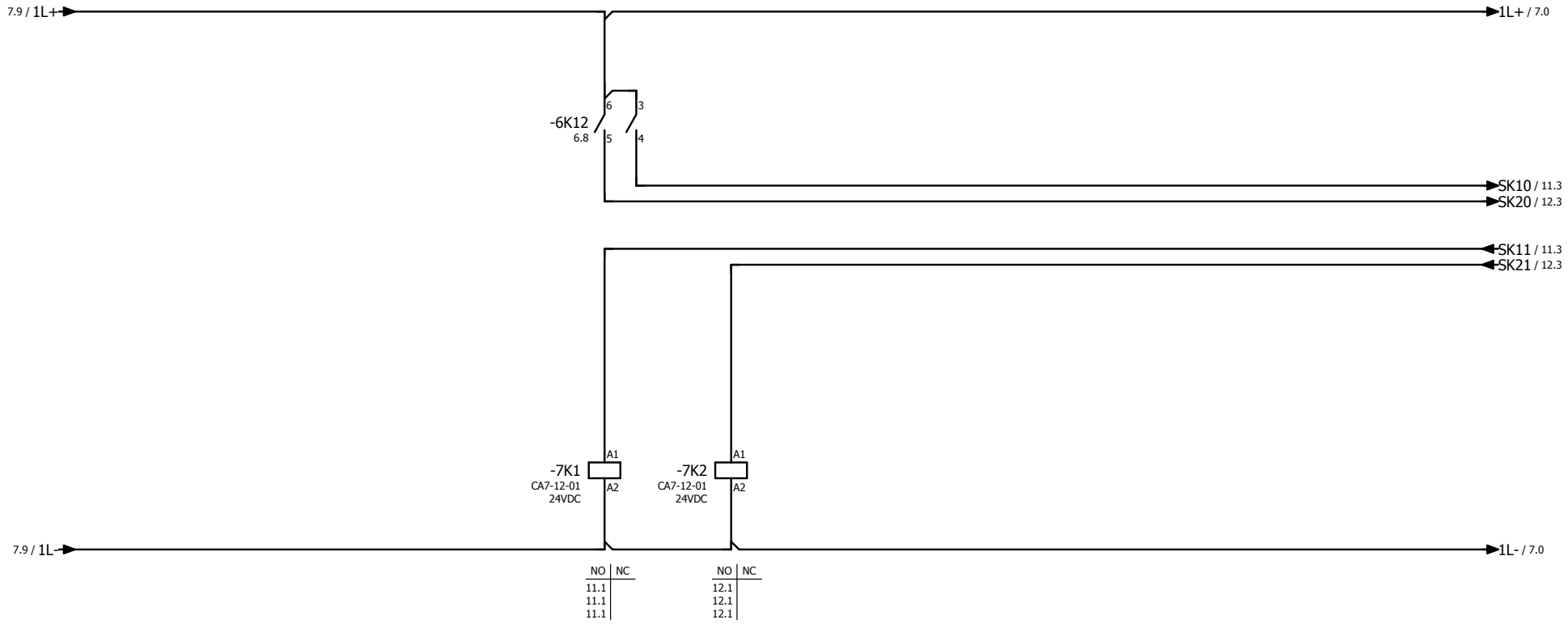

Previous page: 6

Next page: 8

2		
1	Add -7K2	12.01.12
Rev.	Description	Date
Date: 11.04.01		



Viessmann Manufacturing Company Inc.  
750 McMurray Road,  
Waterloo, Ontario N2V 2G5

Project name: Oakland University
Page title: Safety chain evaluation

Project No.: PRJ-00240
Page: 7 of: 103



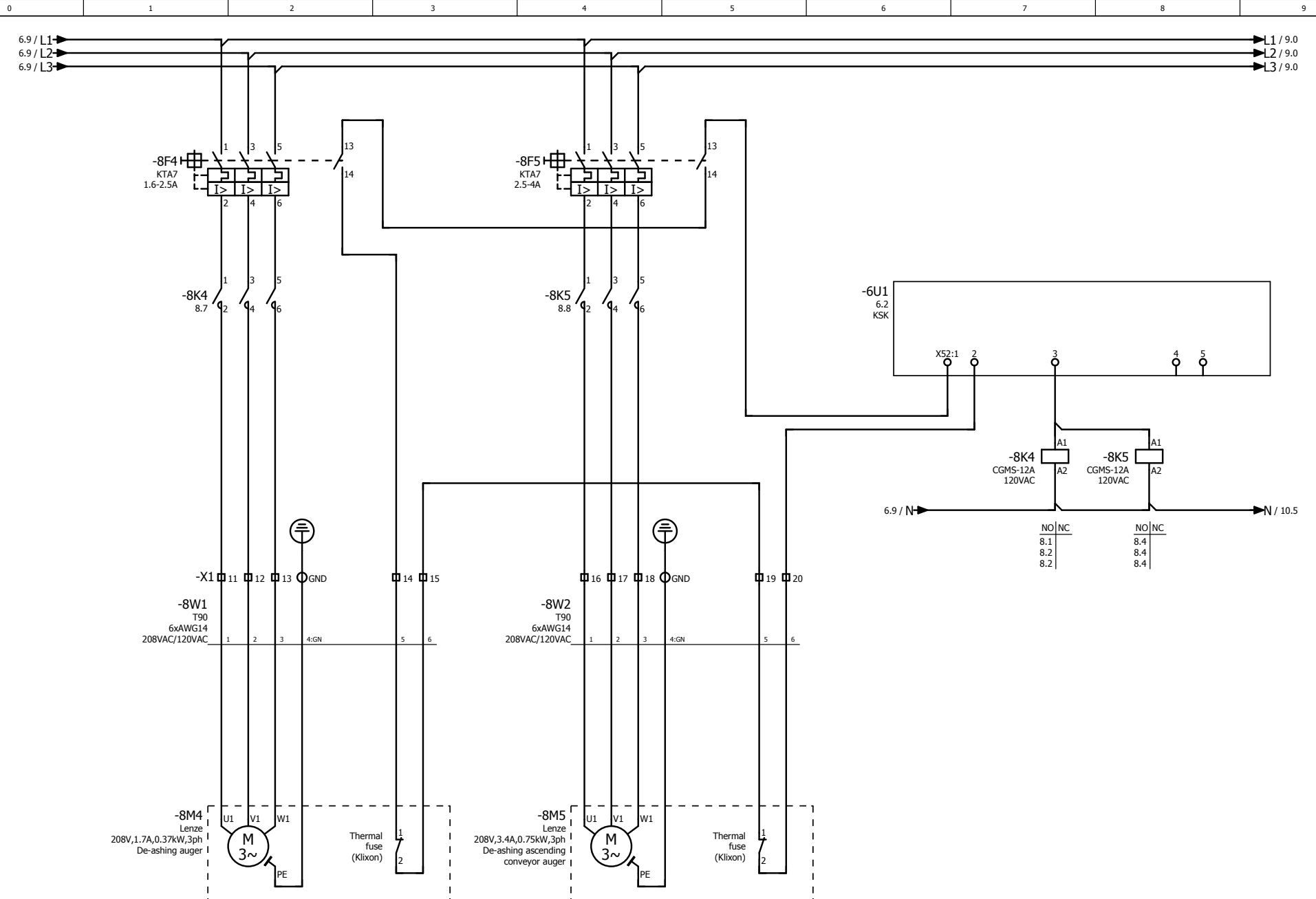

Internal factory wiring. ▲  
 Field connections. ▼

Previous page: 7

Next page: 9

Rev.	Description	Date
2		
1		
		Date: 11.09.15



Viessmann Manufacturing Company Inc.  
 750 McMurray Road,  
 Waterloo, Ontario N2V 2G5

Project name:	Oakland University
Page title:	De-ashing auger M4 De-ashing ascending conveyor auger M5

Project No.:	PRJ-00240
Page:	8 of: 103

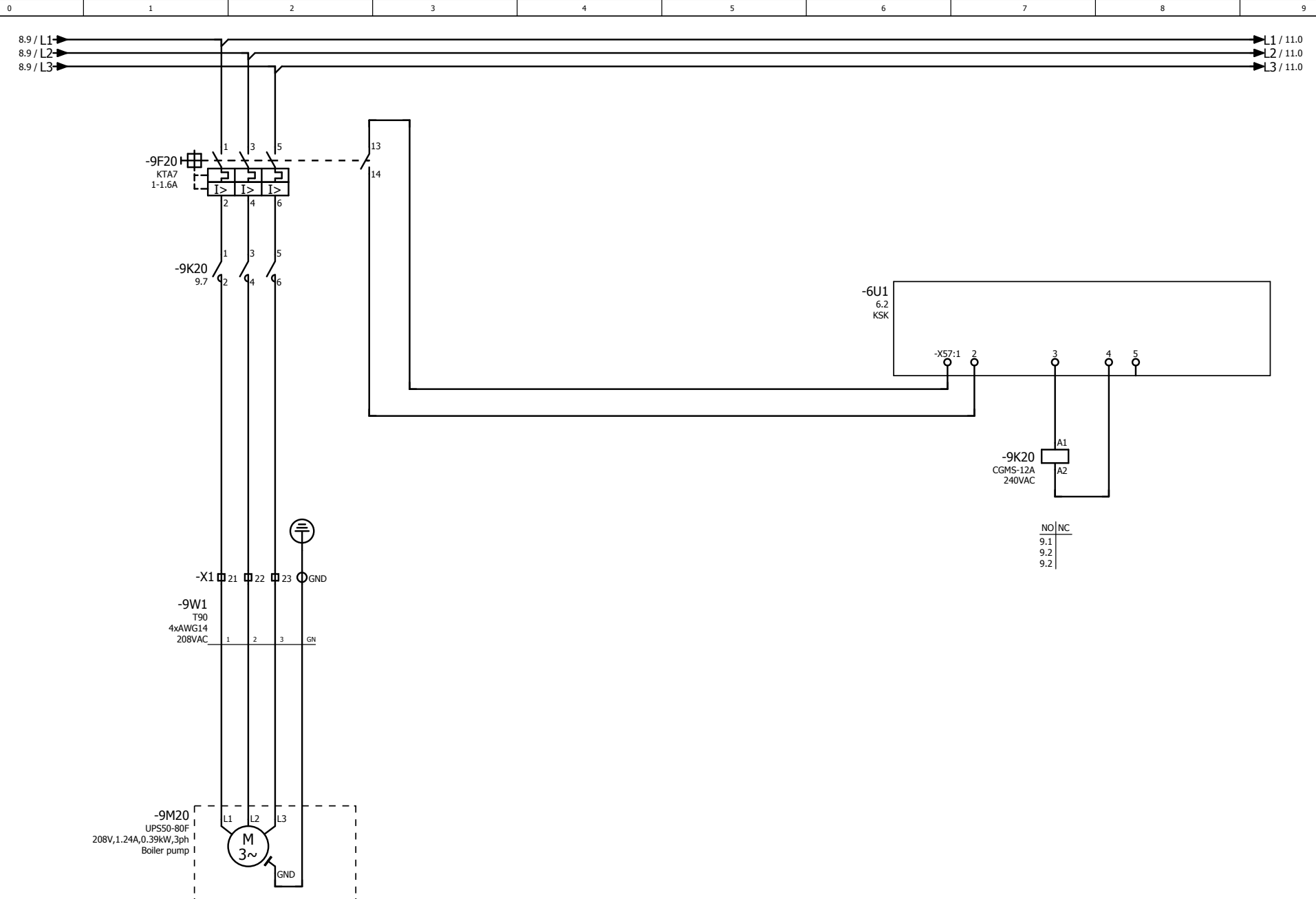

Internal factory wiring. ▲ Field connections.

Previous page: 8

Next page: 10

2		
1		
Rev.	Description	Date
		Date: 11.09.15



Viessmann Manufacturing Company Inc.  
750 McMurray Road,  
Waterloo, Ontario N2V 2G5

Project name: Oakland University  
Page title: Boiler pump

Project No.: PRJ-00240  
Page: 9 of: 103



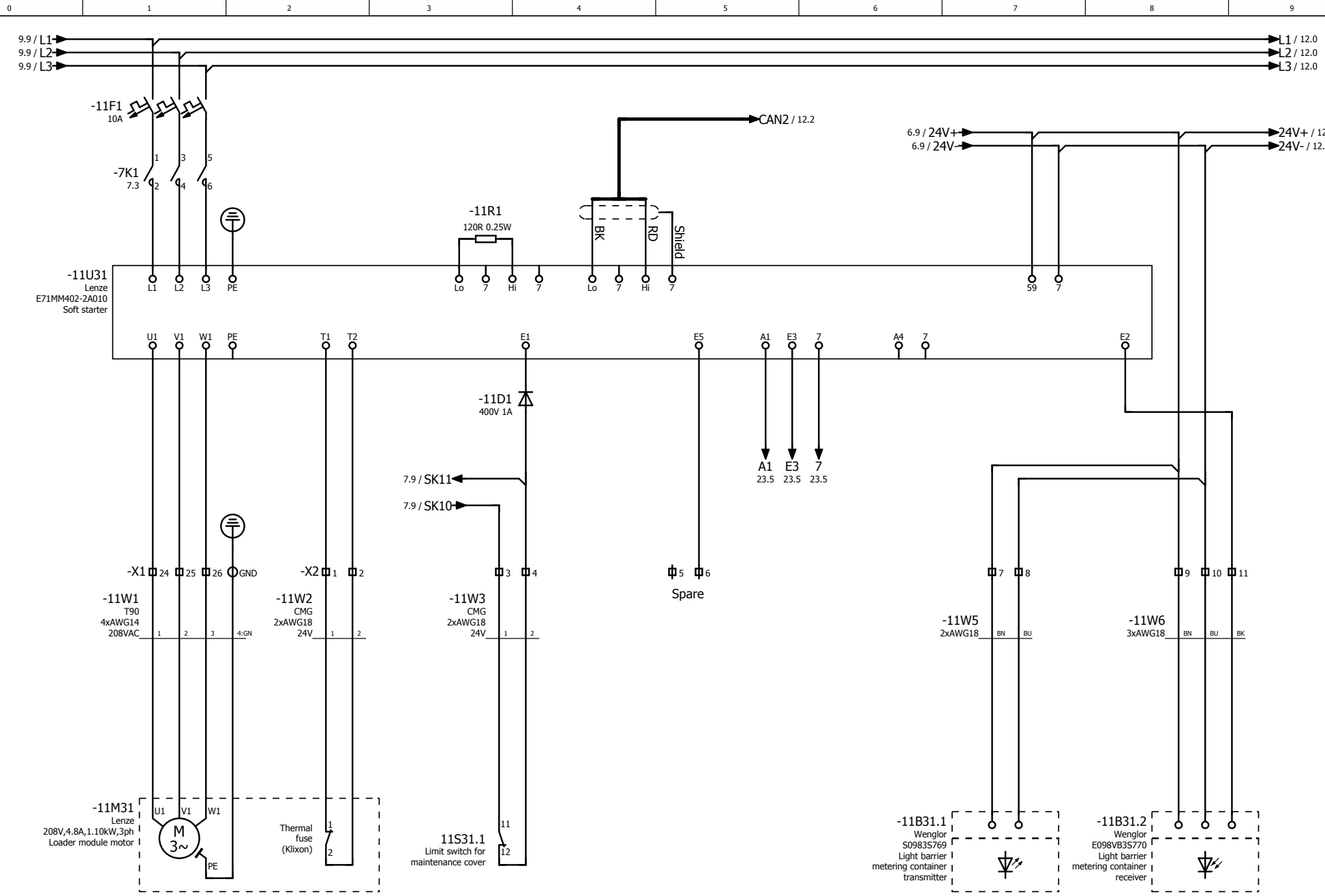

Internal factory wiring.   

 Field connections.

Previous page: 10

Next page: 12

2		
1		
Rev.	Description	Date
		Date: 11.09.15

VIESSMANN

Viessmann Manufacturing Company Inc.  
 750 McMurray Road,  
 Waterloo, Ontario N2V 2G5

Project name:	Oakland University
Page title:	Loader module M31 External loader system T32

Project No.:	PRJ-00240
Page:	11 of: 103

0 1 2 3 4 5 6 7 8 9

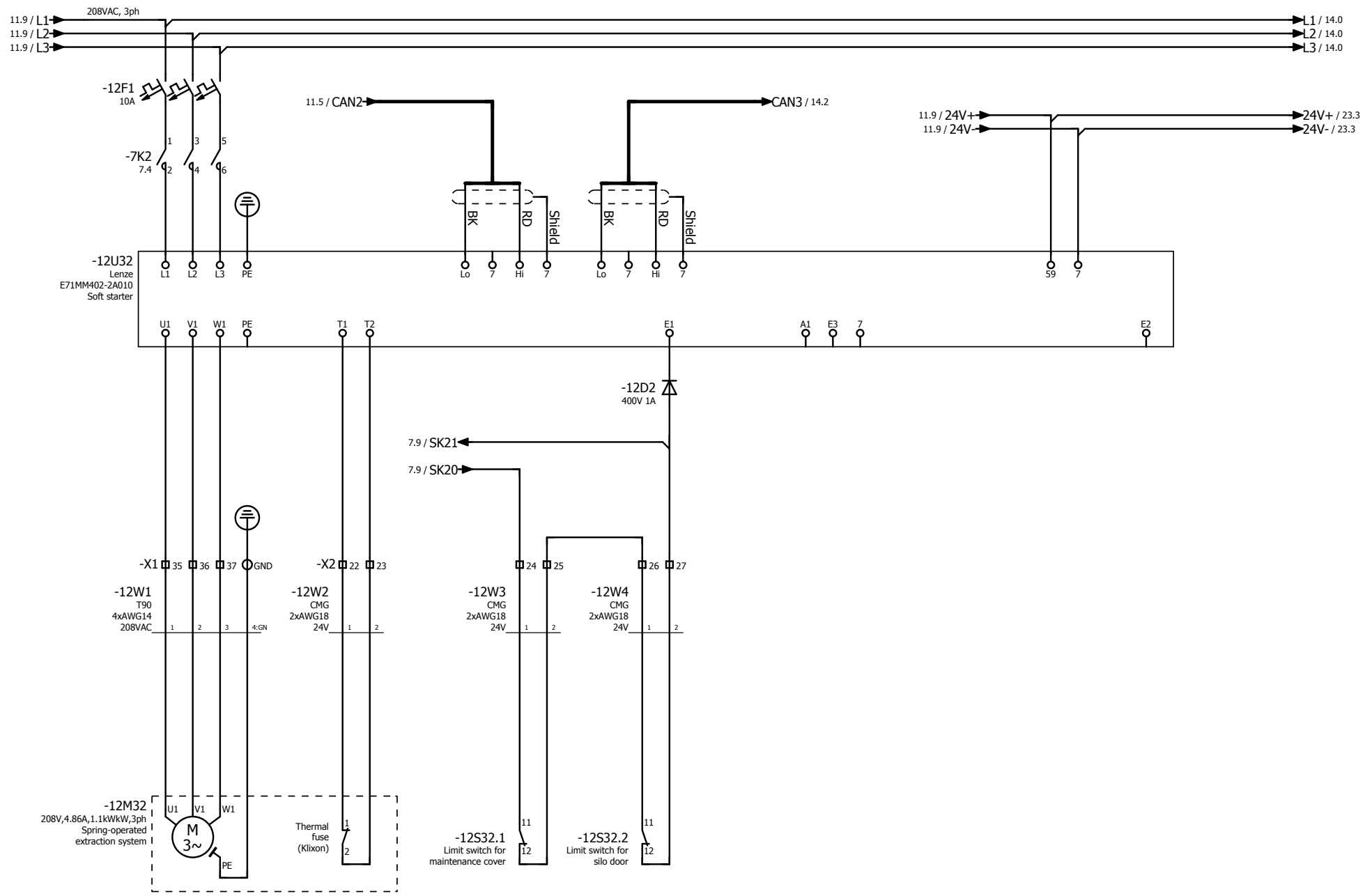

Internal factory wiring.   
  Field connections.

Previous page: 11

Next page: 14

Rev.	Description	Date
2		
1		
		Date: 12.01.12

VIESSMANN

Viessmann Manufacturing Company Inc.  
 750 McMurray Road,  
 Waterloo, Ontario N2V 2G5

Project name: Oakland University
Page title: Spring-operated extraction system T32

Project No.: PRJ-00240
Page: 12 of: 103

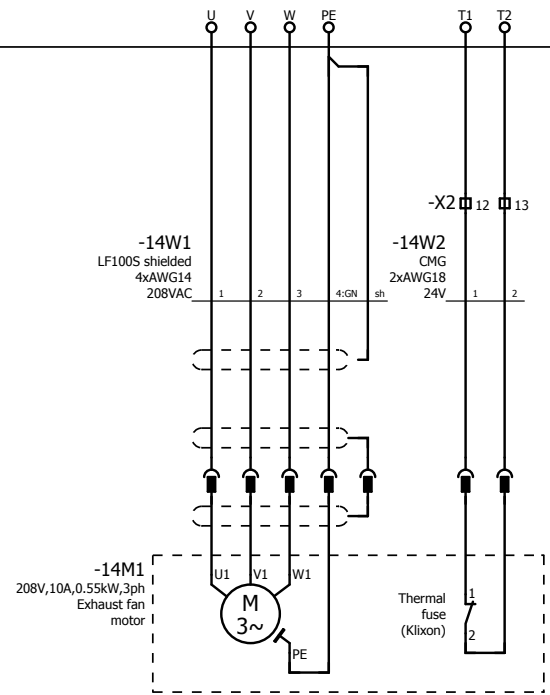
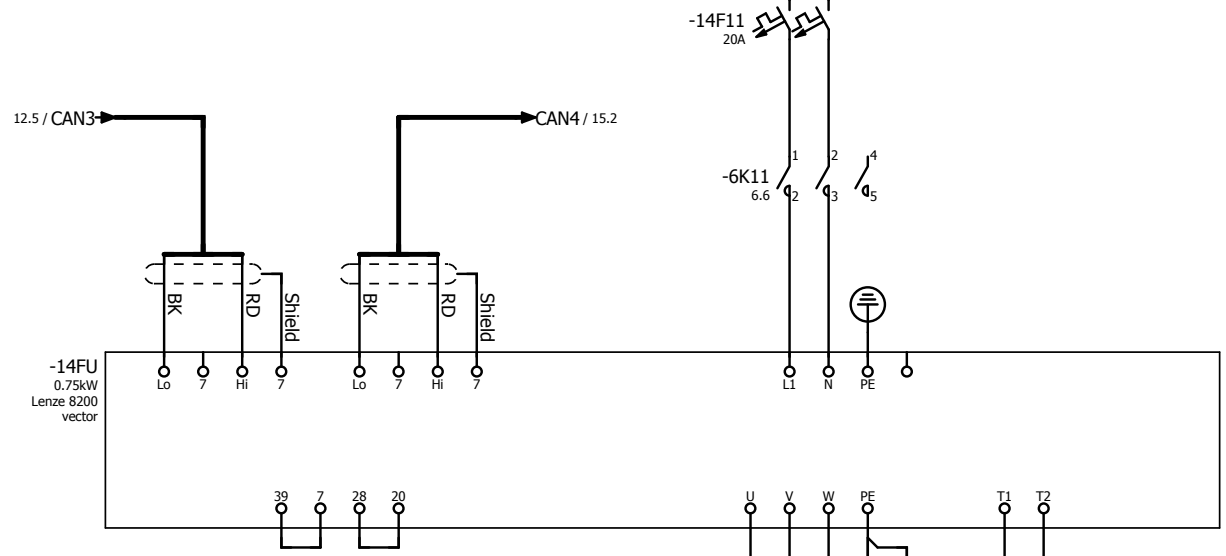
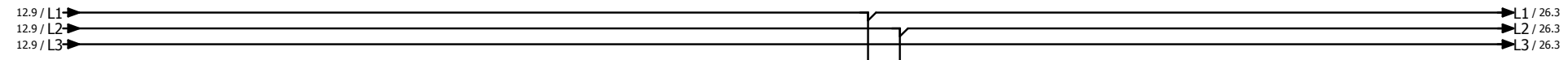

Internal factory wiring. ▲ Field connections.

Previous page: 12

Next page: 15

2		
1		
Rev.	Description	Date
		Date: 11.09.15



Viessmann Manufacturing Company Inc.  
750 McMurray Road,  
Waterloo, Ontario N2V 2G5

Project name: Oakland University  
Page title: Exhaust fan

Project No.: PRJ-00240  
Page: 14 of: 103

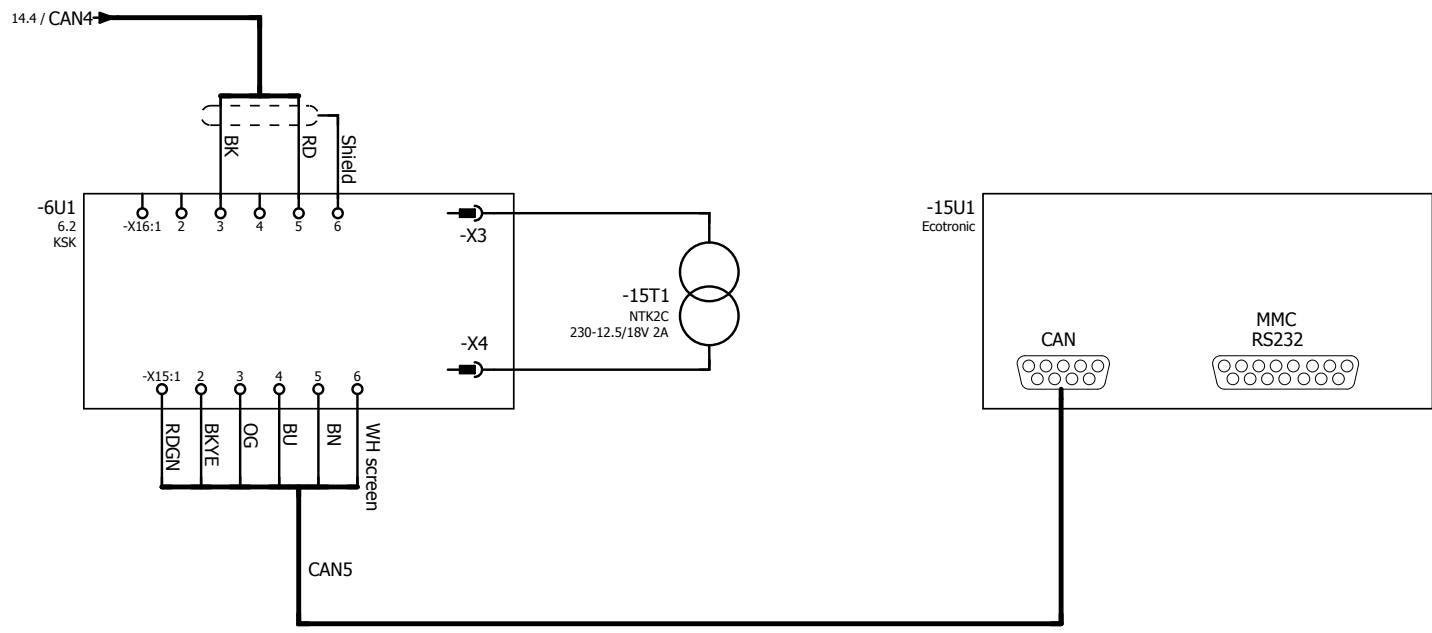

2		
1		
Rev.	Description	Date
		Date: 11.09.15

**VIESSMANN**

Viessmann Manufacturing Company Inc.  
750 McMurray Road,  
Waterloo, Ontario N2V 2G5

Project name: Oakland University
Page title: CAN plug

Project No.: PRJ-00240
Page: 15 of: 103

Internal factory wiring.   Field connections.

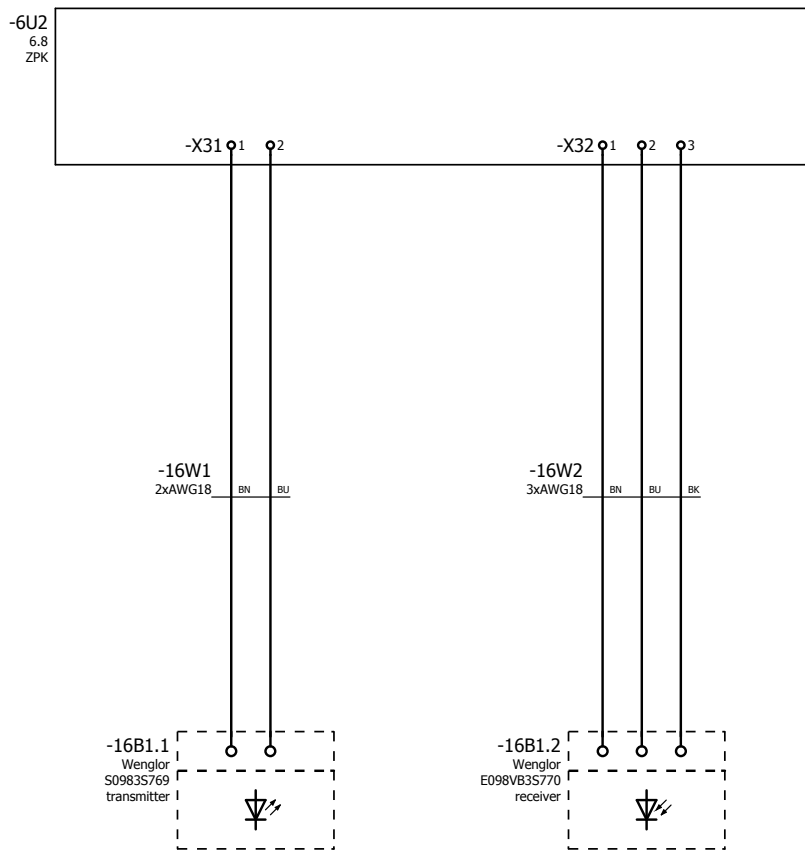

Previous page: 15

Next page: 17

2		
1		
Rev.	Description	Date
		Date: 11.09.15



Viessmann Manufacturing Company Inc.  
750 McMurray Road,  
Waterloo, Ontario N2V 2G5

Project name: Oakland University  
Page title: Light barrier- embers 1 B1

Project No.: **PRJ-00240**  
Page: 16 of: 103



Internal factory wiring.   Field connections.

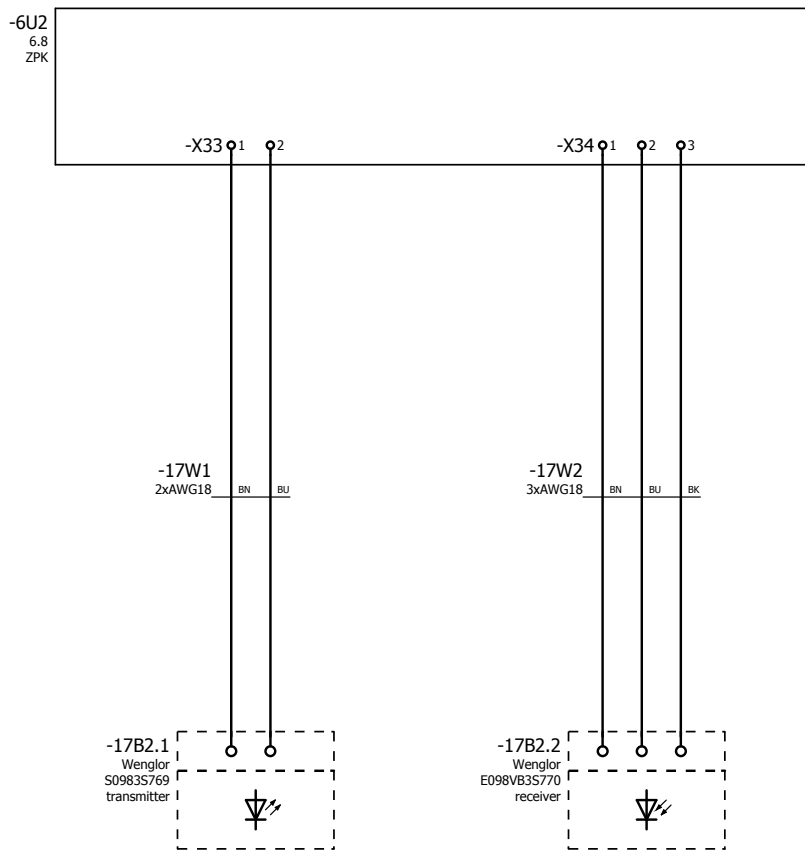

2		
1		
Rev.	Description	Date
		Date: 11.09.15



Viessmann Manufacturing Company Inc.  
750 McMurray Road,  
Waterloo, Ontario N2V 2G5

Project name: Oakland University  
Page title: Light barrier- embers 2 B2

Project No.: **PRJ-00240**  
Page: 17 of: 103

Internal factory wiring.   Field connections.

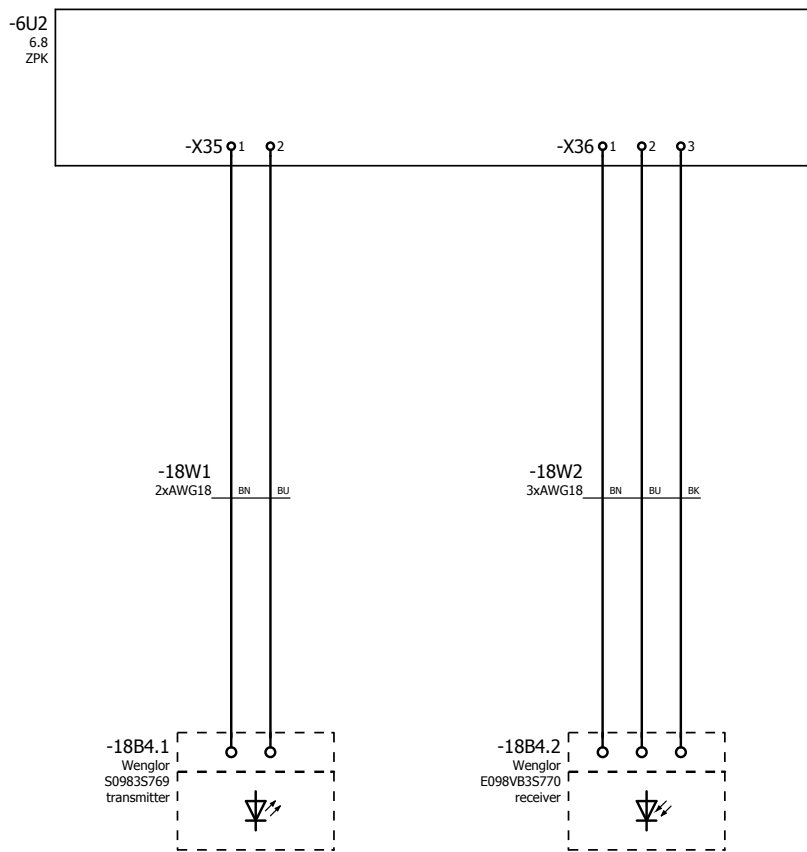

Previous page: 17

Next page: 19

2		
1		
Rev.	Description	Date
		Date: 11.09.15



Viessmann Manufacturing Company Inc.  
750 McMurray Road,  
Waterloo, Ontario N2V 2G5

Project name: Oakland University  
Page title: Light barrier- de-ashing system B4

Project No.: **PRJ-00240**  
Page: 18 of: 103

Internal factory wiring. ▲ ▼ Field connections.

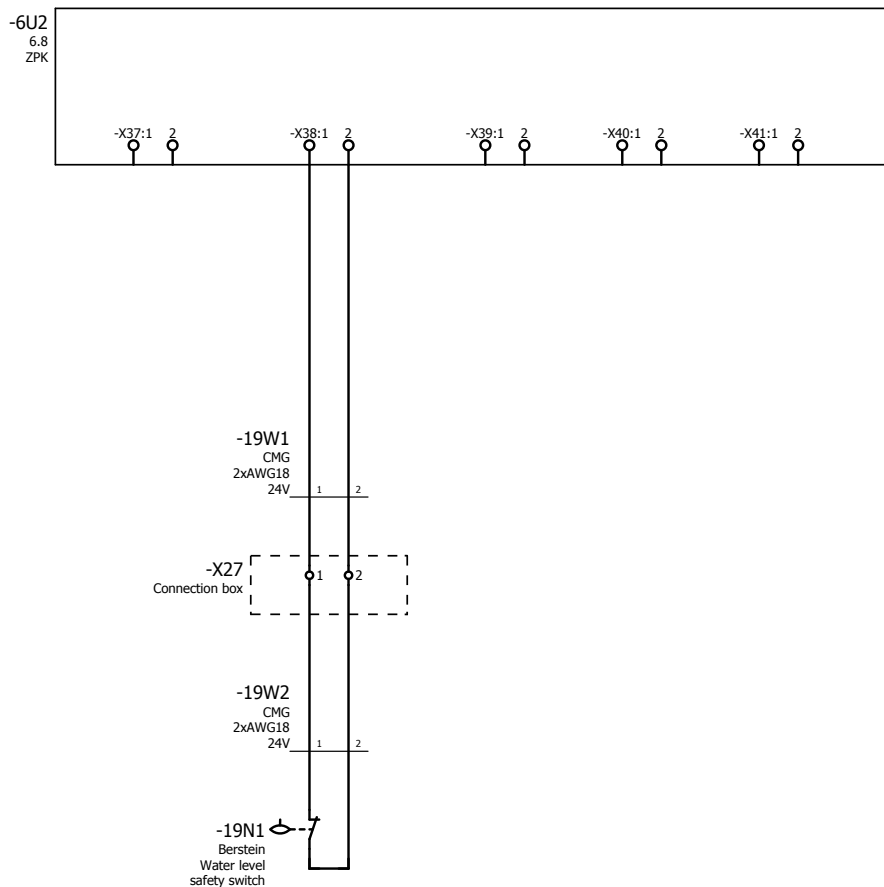

2		
1		
Rev.	Description	Date
		Date: 11.09.15



Viessmann Manufacturing Company Inc.  
750 McMurray Road,  
Waterloo, Ontario N2V 2G5

Project name: Oakland University  
Page title: Water level safety switch N1

Project No.: PRJ-00240  
Page: 19 of: 103

Internal factory wiring.   Field connections.

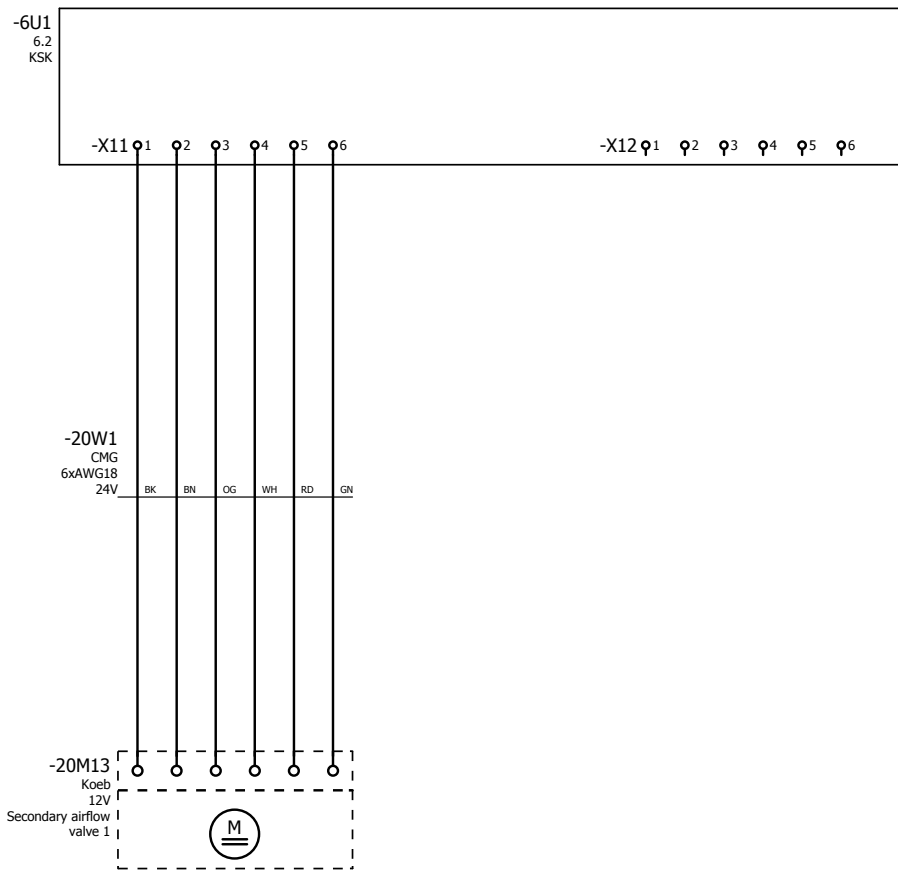

Previous page: 19

Next page: 21

2		
1		
Rev.	Description	Date
		Date: 11.09.15



Viessmann Manufacturing Company Inc.  
750 McMurray Road,  
Waterloo, Ontario N2V 2G5

Project name: Oakland University
Page title: Secondary airflow valve M13

Project No.: PRJ-00240
Page: 20 of: 103

Internal factory wiring.   Field connections.

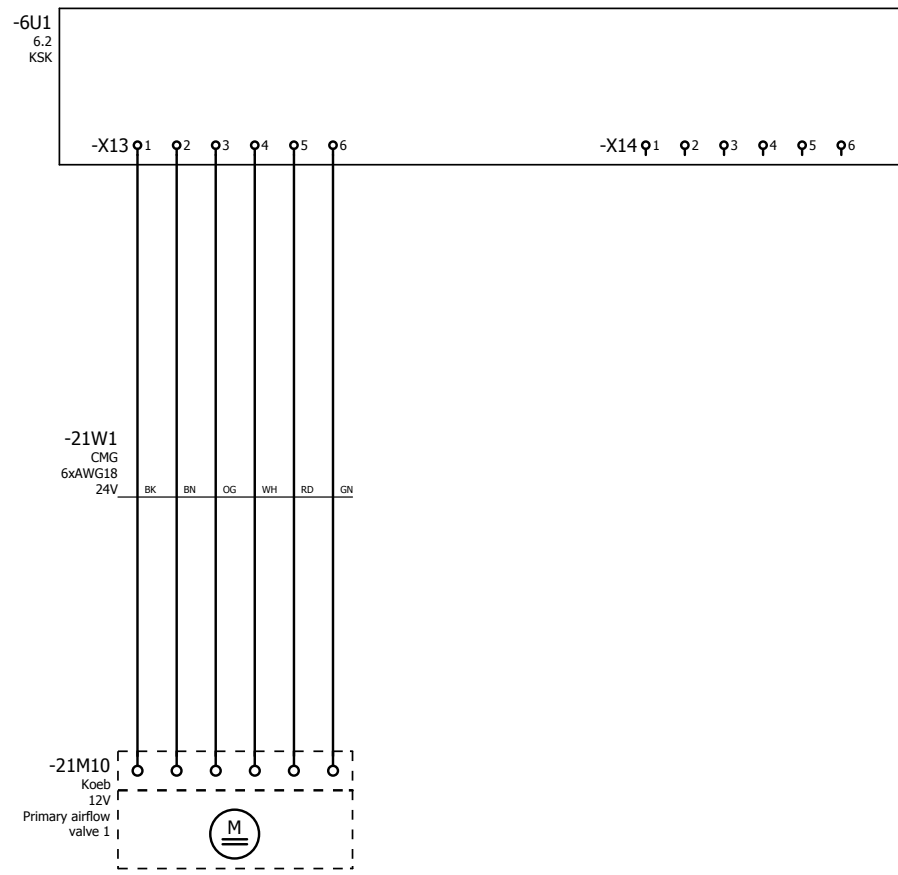

Previous page: 20

Next page: 22

2		
1		
Rev.	Description	Date
		Date: 11.09.15



Viessmann Manufacturing Company Inc.  
750 McMurray Road,  
Waterloo, Ontario N2V 2G5

Project name: Oakland University
Page title: Primary airflow valve M10

Project No.: PRJ-00240
Page: 21 of: 103

Internal factory wiring. ▲ Field connections. ▼

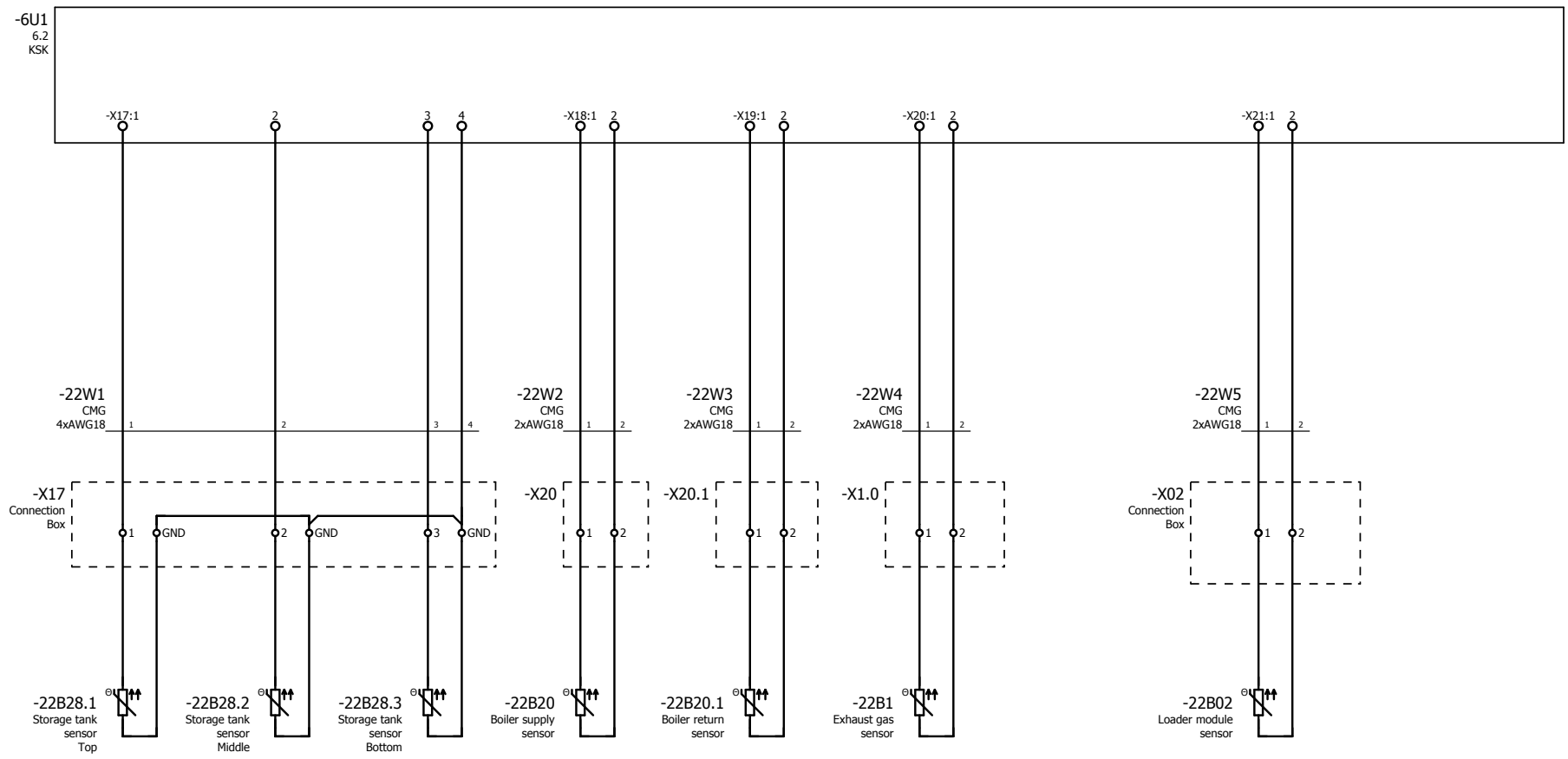

Previous page: 21

Next page: 23

2		
1		
Rev.	Description	Date
		Date: 11.09.15



Viessmann Manufacturing Company Inc.  
750 McMurray Road,  
Waterloo, Ontario N2V 2G5

Project name: Oakland University
Page title: Sensors

Project No.: PRJ-00240
Page: 22 of: 103

Internal factory wiring. ▲ Field connections. ▼

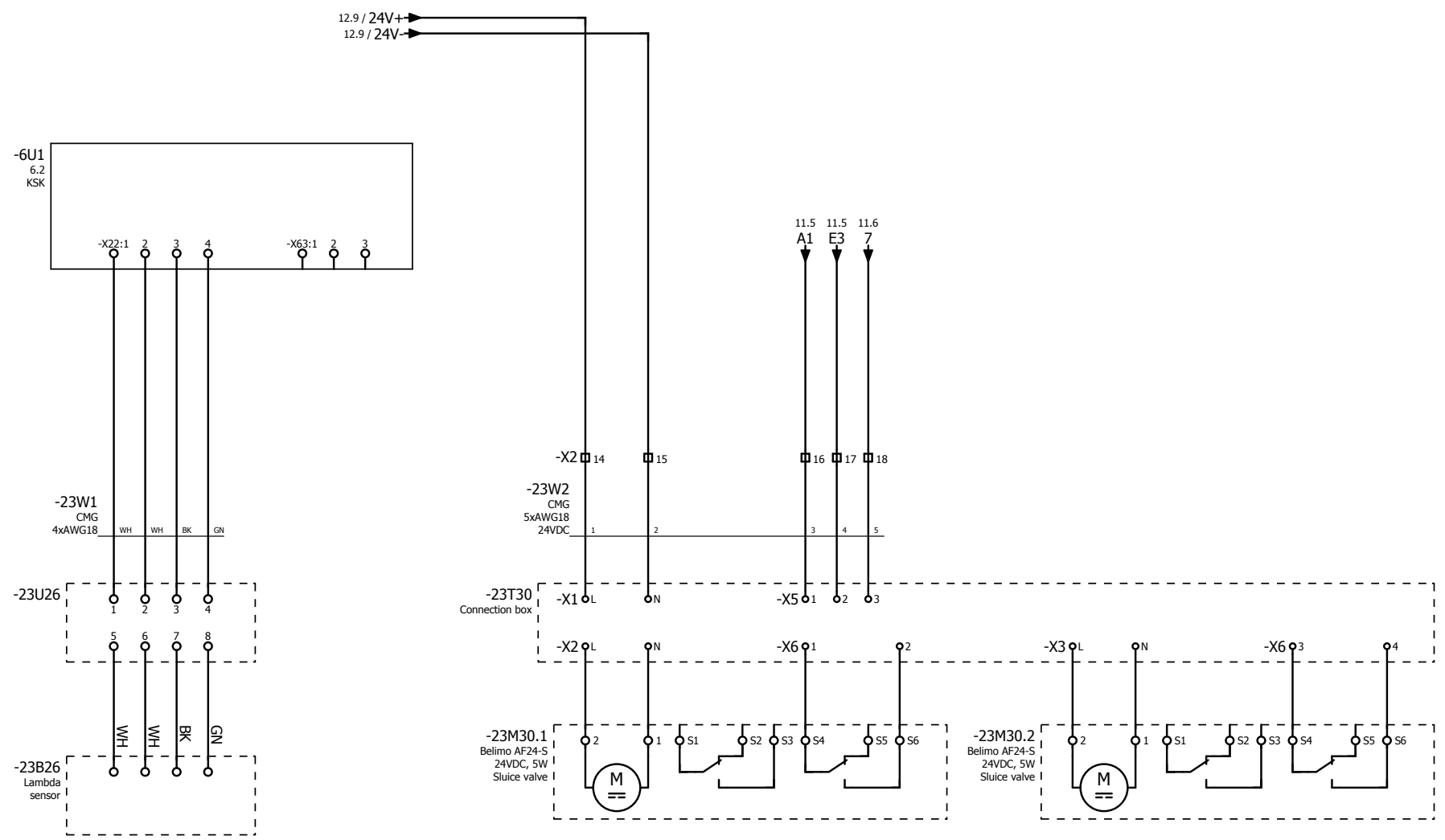

Previous page: 22

Next page: 24

2		
1		
Rev.	Description	Date
		Date: 11.09.15



Viessmann Manufacturing Company Inc.  
750 McMurray Road,  
Waterloo, Ontario N2V 2G5

Project name:	Oakland University
Page title:	Lambda sensor B26 Slide valve T30

Project No.:	PRJ-00240
Page:	23 of: 103

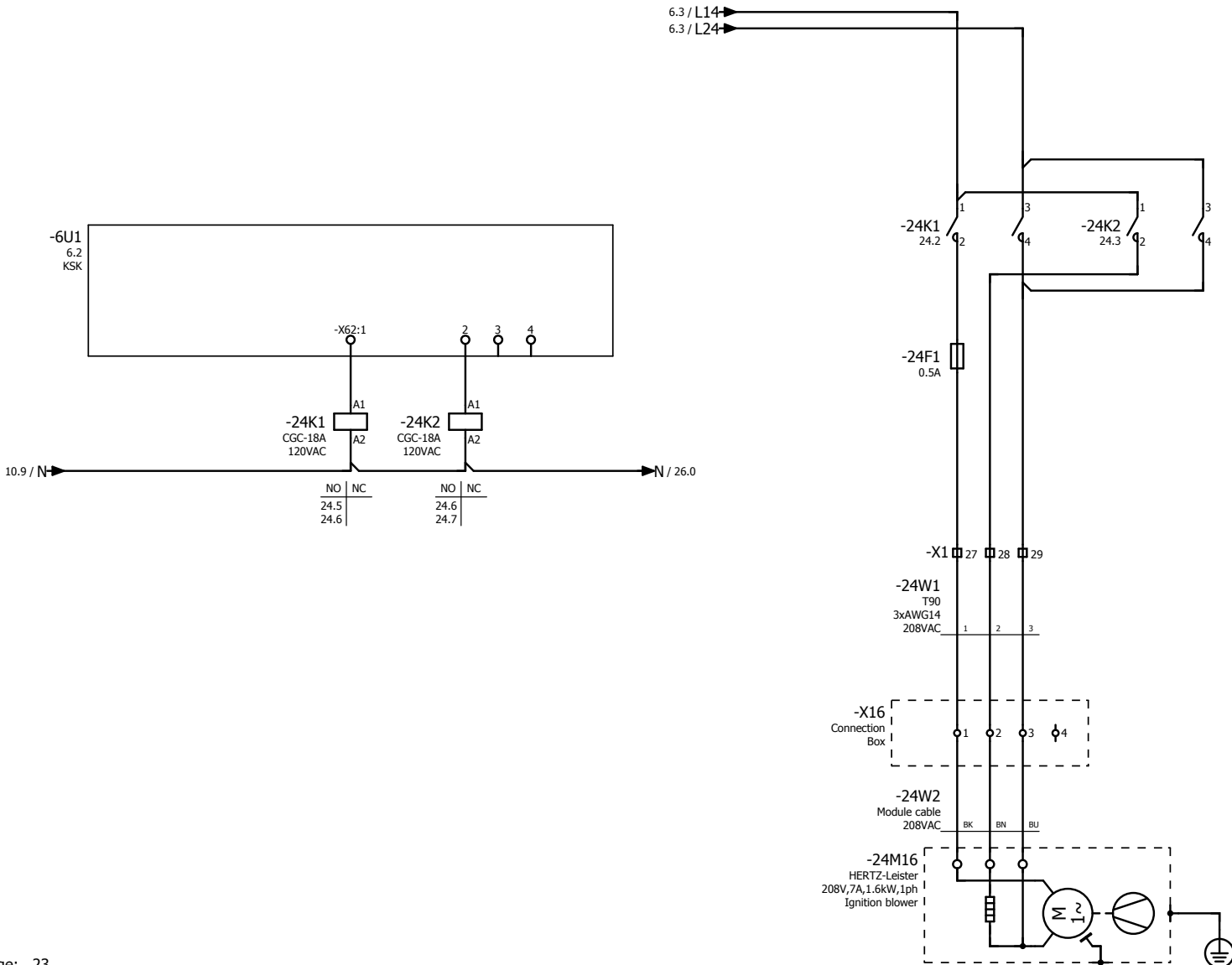

Internal factory wiring.   

 Field connections.

Previous page: 23

Next page: 25

2		
1		
Rev.	Description	Date
		Date: 11.09.15



Viessmann Manufacturing Company Inc.  
 750 McMurray Road,  
 Waterloo, Ontario N2V 2G5

Project name: Oakland University  
 Page title: Ignition blower

Project No.: PRJ-00240  
 Page: 24 of: 103



Internal factory wiring.   Field connections.

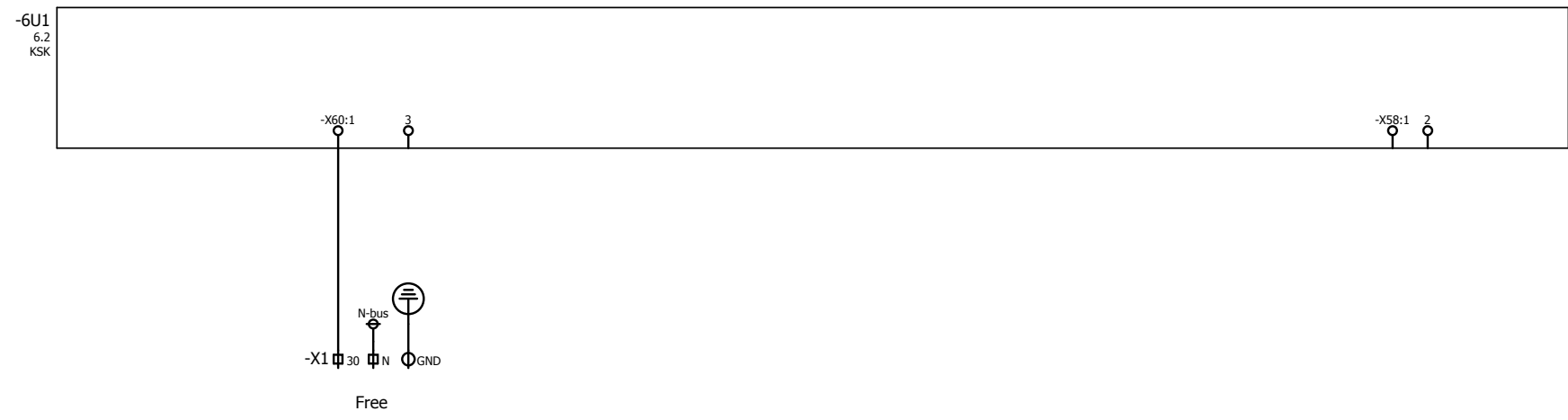

2		
1		
Rev.	Description	Date
		Date: 11.09.15



Viessmann Manufacturing Company Inc.  
750 McMurray Road,  
Waterloo, Ontario N2V 2G5

Project name: Oakland University
Page title: Spare output

Project No.: PRJ-00240
Page: 25 of: 103

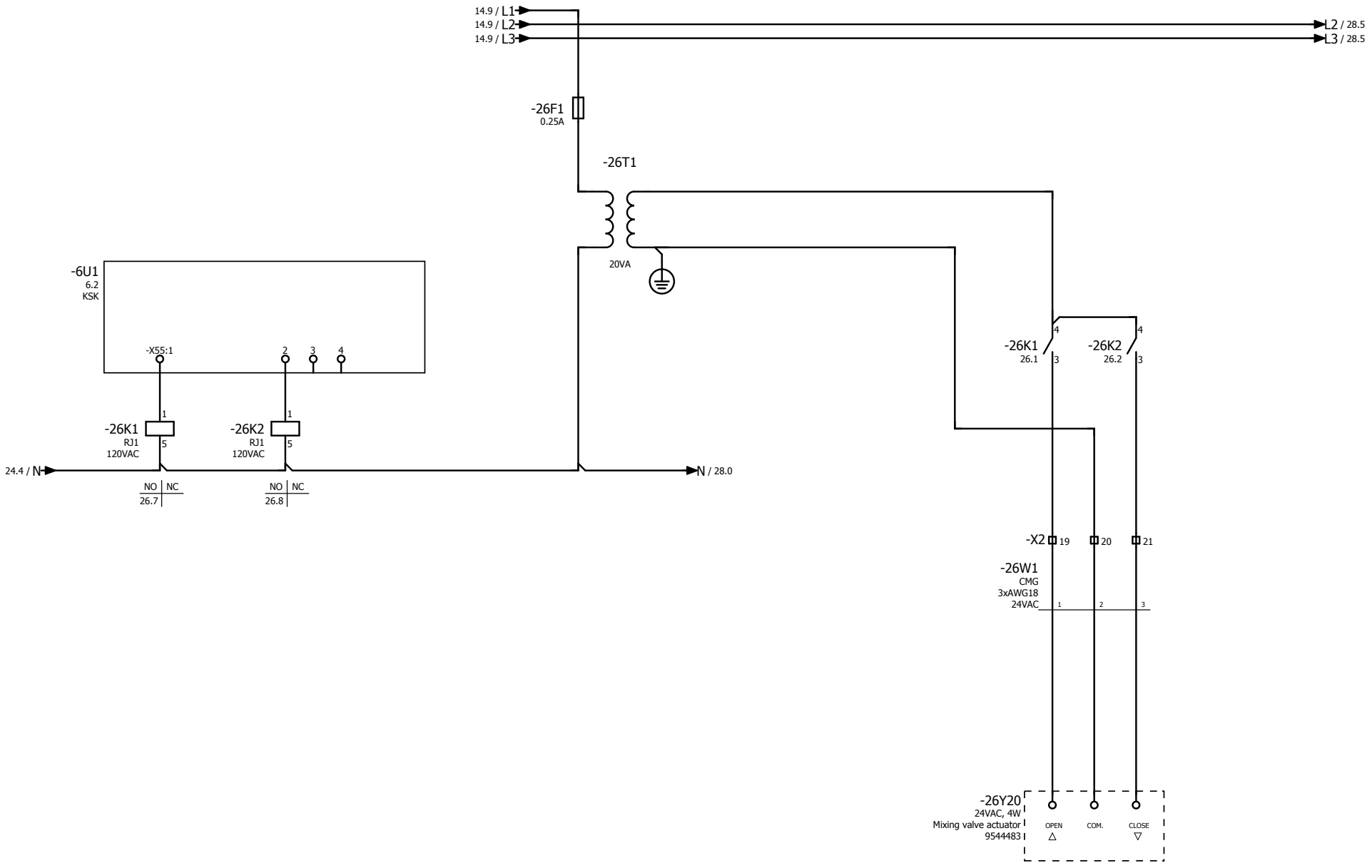

Internal factory wiring.   
  Field connections.

Previous page: 25

Next page: 27

2		
1		
Rev.	Description	Date
		Date: 11.09.15



Viessmann Manufacturing Company Inc.  
750 McMurray Road,  
Waterloo, Ontario N2V 2G5

Project name: Oakland University
Page title: Boiler valve

Project No.: PRJ-00240
Page: 26 of: 103

Internal factory wiring.   Field connections.

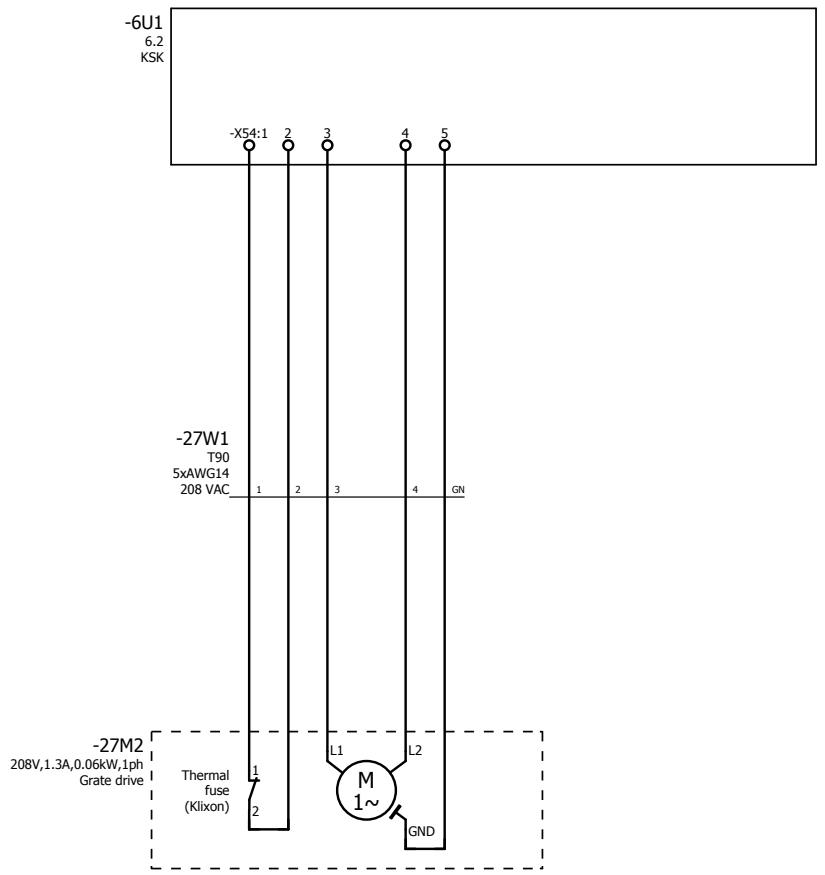

Previous page: 26

Next page: 28

2		
1		
Rev.	Description	Date
		Date: 11.09.15



Viessmann Manufacturing Company Inc.  
750 McMurray Road,  
Waterloo, Ontario N2V 2G5

Project name: Oakland University
Page title: Grate drive M2

Project No.: PRJ-00240
Page: 27 of: 103

Internal factory wiring. ▲ Field connections.

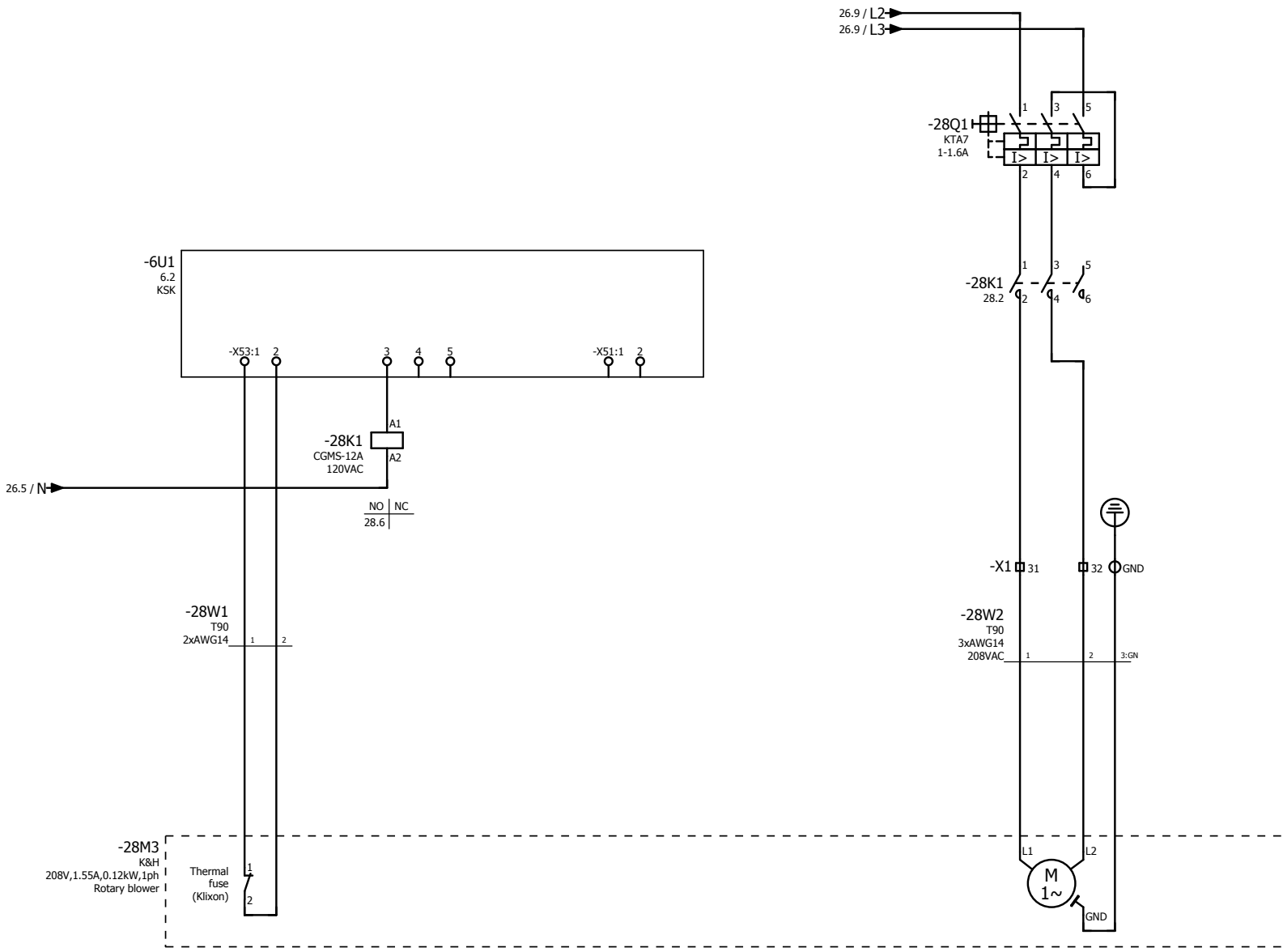

Previous page: 27

Next page: 29

Rev.	Description	Date
2		
1		
		Date: 11.09.15



Viessmann Manufacturing Company Inc.  
750 McMurray Road,  
Waterloo, Ontario N2V 2G5

Project name: Oakland University  
Page title: Rotation blower M3

Project No.: PRJ-00240  
Page: 28 of: 103

Internal factory wiring. ▲ Field connections.

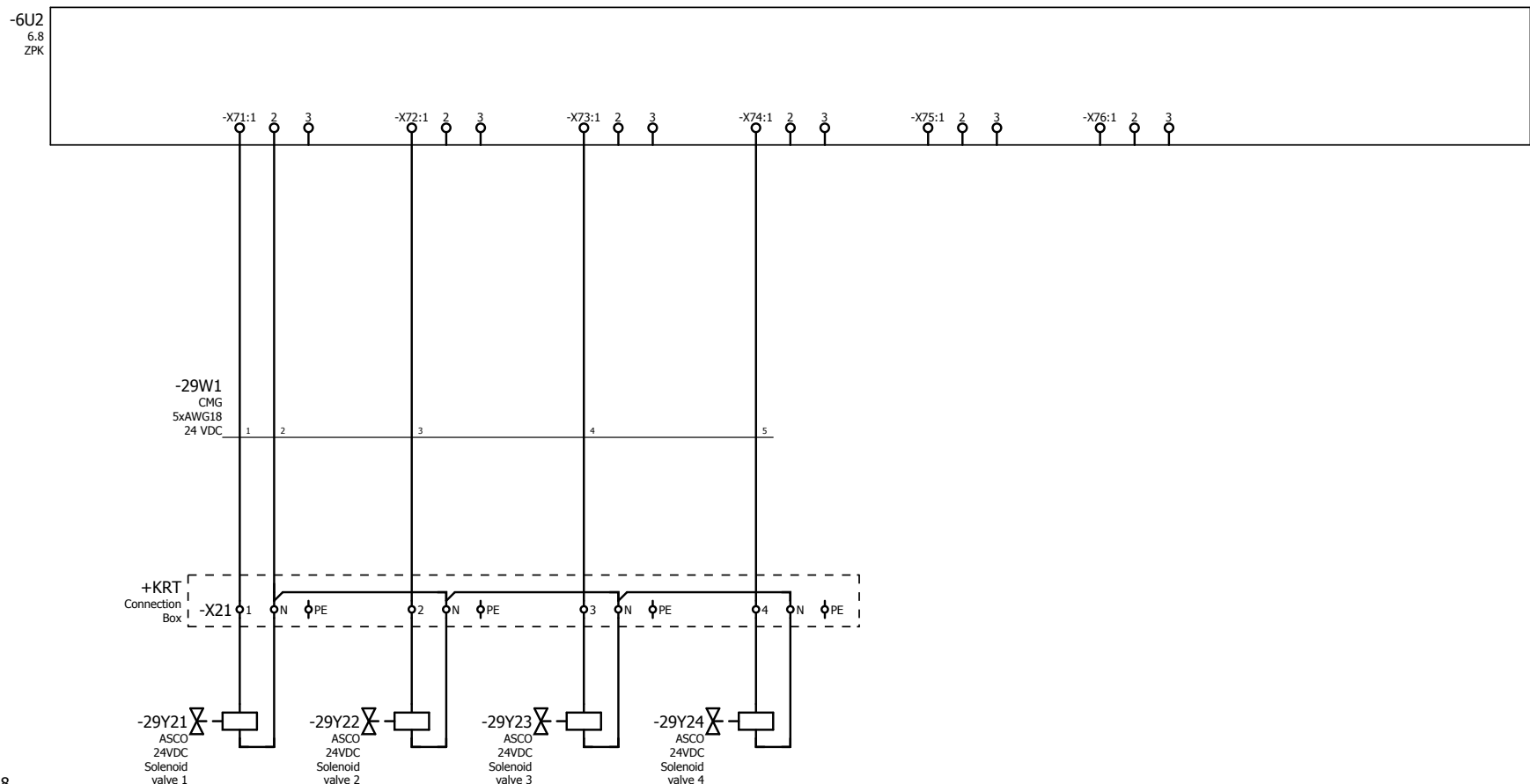

Previous page: 28

Next page: 30

2		
1		
Rev.	Description	Date
		Date: 11.09.15



Viessmann Manufacturing Company Inc.  
750 McMurray Road,  
Waterloo, Ontario N2V 2G5

Project name: Oakland University
Page title: Solenoid valves (pneumatic cleaning system)

Project No.: PRJ-00240
Page: 29 of: 103

Internal factory wiring. ▲ Field connections. ▼

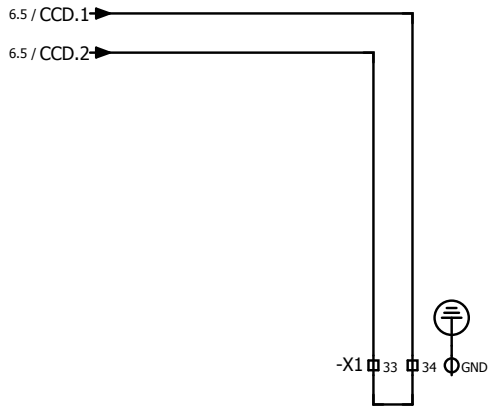

Combustion chamber safety device.  
remove jumper if installed.

Rev.	Description	Date
2		
1		
		Date: 11.09.15



Viessmann Manufacturing Company Inc.  
750 McMurray Road,  
Waterloo, Ontario N2V 2G5

Project name: Oakland University
Page title: Combustion chamber door safety

Project No.: PRJ-00240
Page: 30 of: 103

# Connection/Cable overview

F10\_001

Connection/Cable tag	Source (from)	Target (to)	Wire/Cable type	All conductors	Conductors used	Cross-section [gauge]	Length [ m ]	Remark	Voltage
5W1	5U1	X1	T90	5	5	AWG8		Power supply 208/3/60	208VAC
6W1	X1	6N21	T90	3	3	AWG14		Safety temp. limiter	120VAC
6W2	X1	6N22	T90	5	5	AWG14		Low water cut-off	120VAC
6W3	X1	6N23	T90	3	3	AWG14		Water pressure safety switch	120VAC
8W1	X1	8M4	T90	6	6	AWG14		De-ashing auger	208VAC/120VAC
8W2	X1	8M5	T90	6	6	AWG14		De-ashing ascending conveyor auger	208VAC/120VAC
9W1	X1	9M20	T90	4	4	AWG14		Boiler pump	208VAC
10W1	X3		T90	2	2	AWG14		Fault alarm	250V max.
11W1	X1	11M31	T90	4	4	AWG14		Loader module	208VAC
11W2	X2	11M31	CMG	2	2	AWG18		Loader module thermal fuse	24V
11W3	X2	11S31.1	CMG	2	2	AWG18		Limit switch maintenance cover	24V
11W5	X2	11B31.1		2	2	AWG18		Light barrier metering container transmitter	
11W6	X2	11B31.2		3	3	AWG18		Light barrier metering container receiver	
12W1	X1	12M32	T90	4	4	AWG14		Spring-operated extraction system	208VAC
12W2	X2	12M32	CMG	2	2	AWG18		Spring-operated extraction system thermal fuse	24V
12W3	X2	12S32.1	CMG	2	2	AWG18		Limit switch maintenance cover	24V
12W4	X2	12S32.2	CMG	2	2	AWG18		Limit switch for silo door	24V
14W1	14FU	14M1	LF100S shielded	4	4	AWG14		Exhaust fan	208VAC
14W2	X2	14M1	CMG	2	2	AWG18		Exhaust fan thermal fuse	24V
16W1	6U2-X31	16B1.1		2	2	AWG18		Light barrier embers 1 transmitter	
16W2	6U2-X32	16B1.2		3	3	AWG18		Light barrier embers 1 receiver	
17W1	6U2-X33	17B2.1		2	2	AWG18		Light barrier embers 2 transmitter	
17W2	6U2-X34	17B2.2		3	3	AWG18		Light barrier embers 2 receiver	
18W1	6U2-X35	18B4.1		2	2	AWG18		Light barrier de-ashing system transmitter	
18W2	6U2-X36	18B4.2		3	3	AWG18		Light barrier de-ashing system receiver	
19W1	6U2-X38	X27	CMG	2	2	AWG18		Water level safety switch	24V
19W2	X27	19N1	CMG	2	2	AWG18		=	24V
20W1	6U1-X11	20M13	CMG	6	6	AWG18		Secondary airflow valve 1	24V
21W1	6U1-X13	21M10	CMG	6	6	AWG18		Primary airflow valve 1	24V
22W1	X17	6U1-X17	CMG	4	4	AWG18		Storage tank sensors	
22W2	6U1-X18	X20	CMG	2	2	AWG18		Boiler supply sensor	
22W3	6U1-X19	X20.1	CMG	2	2	AWG18		Boiler return sensor	
22W4	6U1-X20	X1.0	CMG	2	2	AWG18		Exhaust gas sensor	
22W5	6U1-X21	X02	CMG	2	2	AWG18		Loader module sensor	
23W1	6U1-X22	23U26	CMG	4	4	AWG18		Lambda sensor	
23W2	X2	23T30-X1	CMG	5	5	AWG18		Sluice valve	24VDC
		23T30-X5							
24W1	X1	X16	T90	3	3	AWG14		Ignition blower	208VAC
24W2	X16	24M16	Module cable		3			=	208VAC
26W1	X2	26Y20	CMG	3	3	AWG18		Mixing valve	24VAC
27W1	27M2	6U1-X54	T90	5	5	AWG14		Grate drive	208 VAC
28W1	6U1-X53	28M3	T90	2	2	AWG14		Rotary blower thermal fuse	
28W2	X1	28M3	T90	3	3	AWG14		Rotary blower	208VAC
29W1	+KRT-X21	6U2-X71	CMG	5	5	AWG18		Solenoid valves	24 VDC
		6U2-X72							
		6U2-X73							

Previous page: 30

Next page: 50.1

2		
1		12.01.12
Rev.	Description	Date
		Date: 11.09.15



Viesmann Manufacturing Company Inc.  
750 McMurray Road,  
Waterloo, Ontario N2V 2G5

Project name: Oakland University  
Page title: Cable overview : 5W1 - 29W1

Project No.:  
**PRJ-00240**

Page: 50 of: 103





# Terminal diagram

F13\_001

Function text	11W1	9W1	8W2	8W1	6W3	6W2	6W1	5W1	Connection tag	Strip X1 Line voltage connections					Page / column	
	T90	T90	T90	T90	T90	T90	T90	T90		Wire/Cable type	External Target designation	Connection point	Terminal	Jumper		Internal Target designation
Power supply 208/3/60								1		5U1	L1	1	*	5Q1	L1	5.1
=								2		5U1	L2	2	*	5Q1	L2	5.1
=								3		5U1	L3	3	*	5Q1	L3	5.1
=								WH		5U1	N	N	*		N-bus	5.1
=								GN		5U1	G	GND	*			5.1
Safety temp. limiter (STL)								1		6N21		4	*	6U1-X59	1	6.2
=								2		6N21		5	*	6U1-X59	2	6.3
=								3:GN		6N21	GND	GND	*			6.3
Low water cut-off						1:WH				6N22	L2	N	*		N-bus	6.4
=						2				6N22	L1	6	*	6F1		6.4
=						3				6N22	P1	7	*	6U1-X59	3	6.4
=						4				6N22	P2	8	*			6.4
=						5:GN				6N22	GND	GND	*			6.5
Water safety pressure switch					1					6N23		9	*	6U1-X59	5	6.6
=					2					6N23		10	*	6U1-X59	6	6.6
=					3:GN					6N23	GND	GND	*			6.6
De-ashing auger				1						8M4	U1	11	*	8K4	2	8.1
=				2						8M4	V1	12	*	8K4	4	8.2
=				3						8M4	W1	13	*	8K4	6	8.2
=				4:GN						8M4	PE	GND	*			8.2
De-ashing auger thermal fuse				5						8M4	1	14	*	8F4	14	8.3
=				6						8M4	2	15	*			8.3
De-ashing ascending conveyor auger			1							8M5	U1	16	*	8K5	2	8.4
=			2							8M5	V1	17	*	8K5	4	8.4
=			3							8M5	W1	18	*	8K5	6	8.4
=			4:GN							8M5	PE	GND	*			8.5
De-ashing ascending conveyor auger thermal fuse			5							8M5	1	19	*			8.5
=			6							8M5	2	20	*	6U1-X52	2	8.5
Boiler pump		1								9M20	L1	21	*	9K20	2	9.1
=		2								9M20	L2	22	*	9K20	4	9.2
=		3								9M20	L3	23	*	9K20	6	9.2
=		GN								9M20	GND	GND	*			9.2
Loader module	1									11M31	U1	24	*	11U31	U1	11.1
=	2									11M31	V1	25	*	11U31	V1	11.1
=	3									11M31	W1	26	*	11U31	W1	11.1

Previous page: 50.1

Next page: 59.1

2		
1		
Rev.	Description	Date
		Date: 11.09.15



Viessmann Manufacturing Company Inc.  
750 McMurray Road,  
Waterloo, Ontario N2V 2G5

Project name: Oakland University  
Page title: Terminal diagram : X1

Project No.: PRJ-00240  
Page: 59 of: 103

# Terminal diagram

F13\_001

Strip X1 Line voltage connections										
Function text	11W1	12W1	24W1	28W2	190	190	190	190	190	Page / column
	Connection tag	Wire/Cable type	External Target designation	Connection point	Terminal	Jumper	Internal Target designation	Connection point		
Loader module	4:GN		11M31	PE	GND	*			11.2	
Spring-operated extraction system			12M32	U1	35	*	12U32	U1	12.1	
=			12M32	V1	36	*	12U32	V1	12.1	
=			12M32	W1	37	*	12U32	W1	12.1	
=			12M32	PE	GND	*			12.2	
Ignition blower			X16	1	27	*	24F1		24.5	
=			X16	2	28	*	24K2	2	24.6	
=			X16	3	29	*	24K1	4	24.6	
Spare					30	*	6U1-X60	1	25.2	
=					N	*		N-bus	25.2	
=					GND	*			25.2	
Rotary blower			28M3	L1	31	*	28K1	2	28.6	
=			28M3	L2	32	*	28K1	4	28.6	
=			28M3	GND	GND	*			28.6	
Combustion chamber door safety					33	*			30.3	
=					34	*	6U1-X59	4	30.3	
=					GND	*			30.3	

Previous page: 59

Next page: 60

2		
1		12.01.12
Rev.	Description	Date
		Date: 11.09.15

**VIESSMANN**  
 Viessmann Manufacturing Company Inc.  
 750 McMurray Road,  
 Waterloo, Ontario N2V 2G5

Project name:	Oakland University
Page title:	Terminal diagram : X1

Project No.:	PRJ-00240
Page:	59.1 of: 103

# Terminal diagram

F13\_001

Function text	Connection tag							Strip X2 24V connections					Page / column		
	14W2	12W4	12W3	12W2	11W6	11W5	11W3	11W2	Wire/Cable type	External Target designation	Connection point	Terminal		Jumper	Internal Target designation
Loader module thermal fuse								CMG	11M31	1	1	*	11U31	T1	11.2
=								CMG	11M31	2	2	*	11U31	T2	11.2
Limit switch for maintenance cover								CMG	11S31.1	11	3	*	6K12	4	11.3
=								CMG	11S31.1	12	4	*	11D1		11.4
Spare											5	*			11.5
=											6	*	11D2		11.5
Light barrier metering container- transmitter								BN	11B31.1		7	┌───┐ └───┘			11.7
=								BU	11B31.1		8				11.7
Light barrier metering container- receiver								BN	11B31.2		9	┌───┐ └───┘	11U31	59	11.8
=								BU	11B31.2		10			11U31	7
=								BK	11B31.2		11	*	11U31	E2	11.9
Spring-operated extraction system thermal fuse				1					12M32	1	22	*	12U32	T1	12.2
=				2					12M32	2	23	*	12U32	T2	12.2
Limit switch for maintenance cover			1						12S32.1	11	24	*	6K12	5	12.4
=			2						12S32.1	12	25	┆ ┆ ┆			12.4
Limit switch for silo door		1							12S32.2	11	26				
=		2							12S32.2	12	27	*	12D2		12.5
Exhaust fan thermal fuse	1								14M1	1	12	*	14FU	T1	14.6
=	2								14M1	2	13	*	14FU	T2	14.6

Previous page: 59.1

Next page: 60.1

2		
1		12.01012
Rev.	Description	Date
		Date: 11.09.15



Viessmann Manufacturing Company Inc.  
750 McMurray Road,  
Waterloo, Ontario N2V 2G5

Project name:	Oakland University
Page title:	Terminal diagram : X2

Project No.:	PRJ-00240
Page:	60 of 103





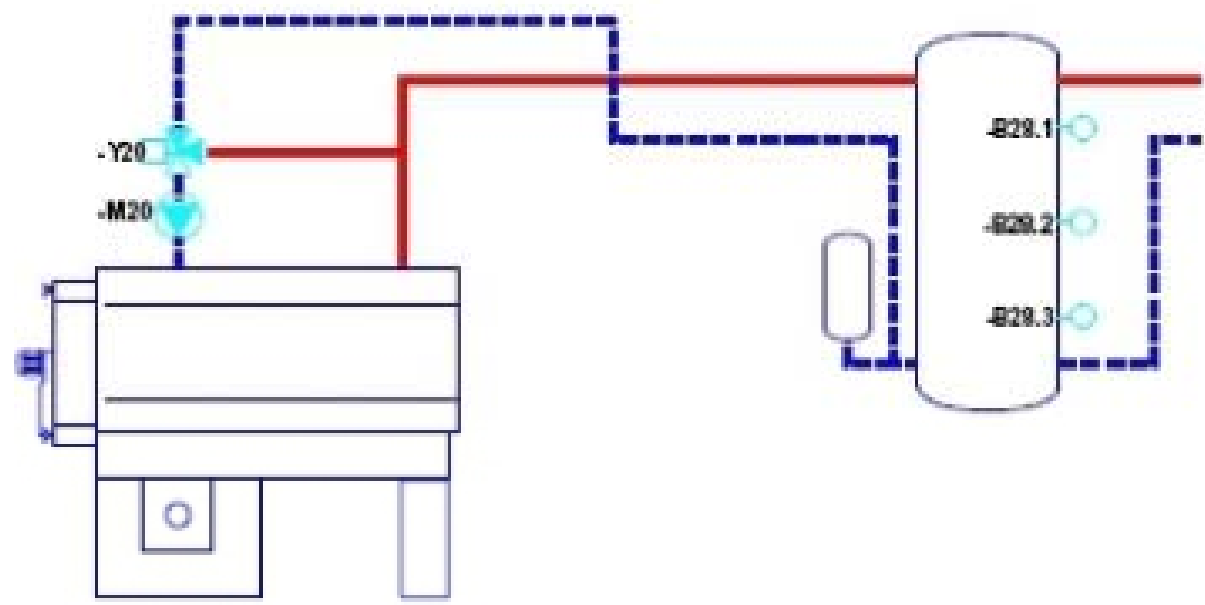
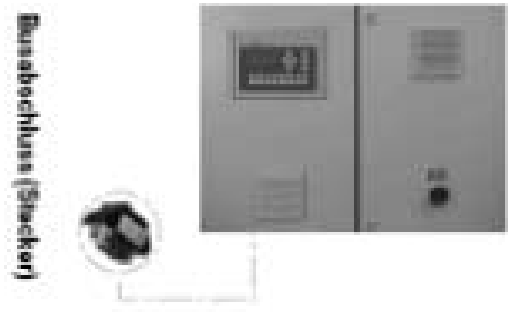

2		
1		
Rev.	Description	Date
		Date: 11.09.15



Viessmann Manufacturing Company Inc.  
750 McMurray Road,  
Waterloo, Ontario N2V 2G5

Project name: Oakland University
Page title: Schematic diagram

Project No.: PRJ-00240
Page: 100 of: 103

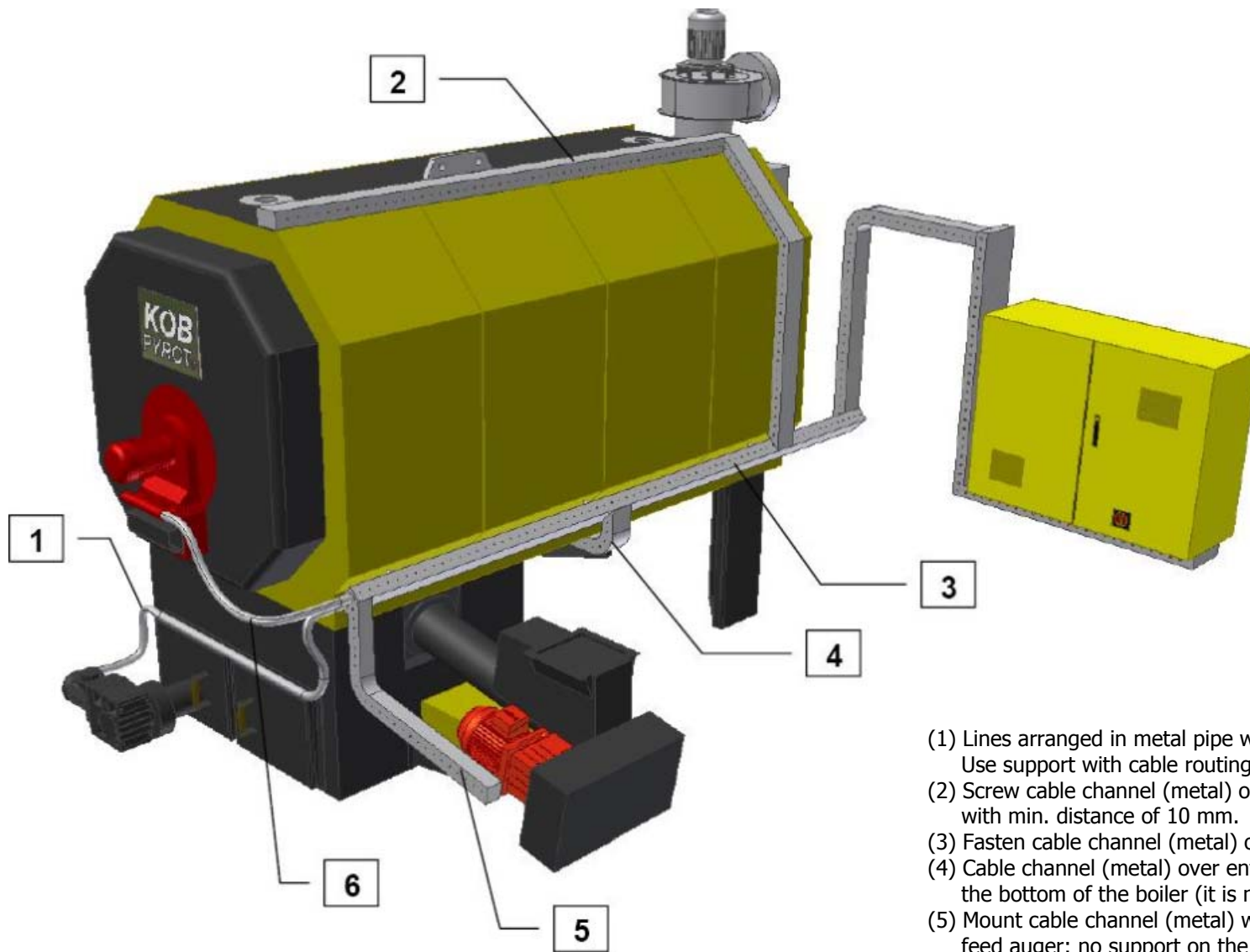

- (1) Lines arranged in metal pipe with min distance of 150 mm to the base. Use support with cable routing for light barrier. No support on base.
- (2) Screw cable channel (metal) onto the foot plate on top of the boiler with min. distance of 10 mm.
- (3) Fasten cable channel (metal) on casing with min. distance of 20 mm.
- (4) Cable channel (metal) over entire width of the boiler: fastening on the bottom of the boiler (it is not water-bearing).
- (5) Mount cable channel (metal) with min. distance of 200 mm to the feed auger: no support on the feed auger.
- (6) Arrange lines in protective flexible cable conduit with sufficient leeway to open and close the door (mind the door stop).

2		
1		
Rev.	Description	Date
		Date: 11.09.15



Viessmann Manufacturing Company Inc.  
750 McMurray Road,  
Waterloo, Ontario N2V 2G5

Project name: Oakland University

Page title: Arrangement of electrical wiring

Project No.: PRJ-00240

Page: 101 of: 103

# Boiler PYROT

+KRT

Boiler

+T31 - Txx

PYROT transport equipment

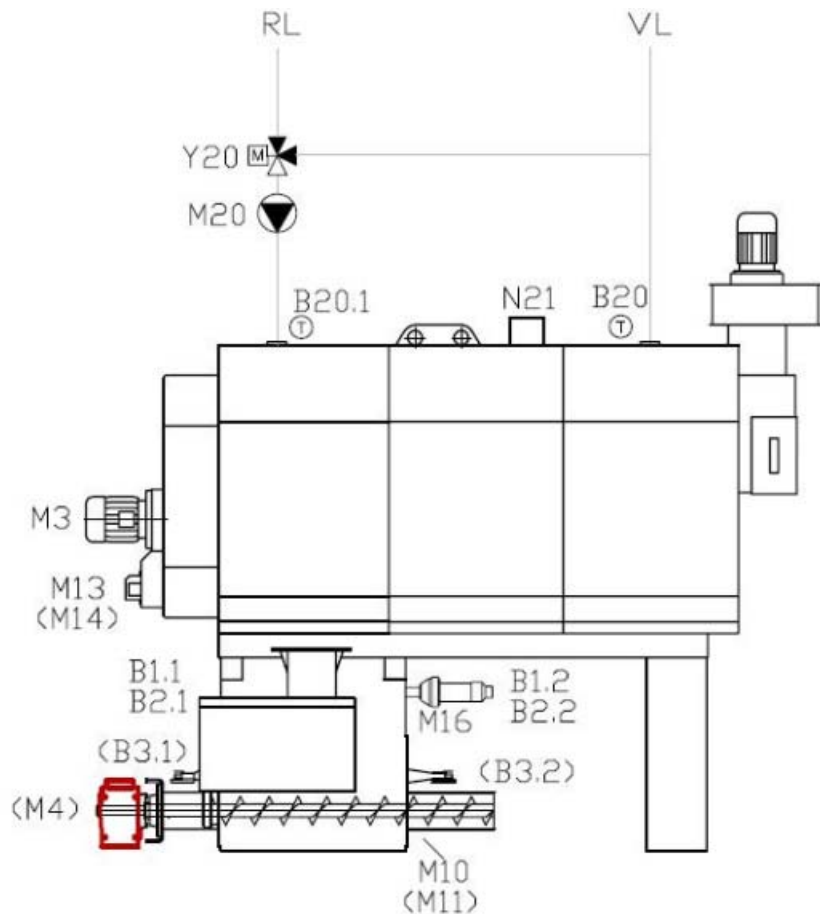

**+KRT**

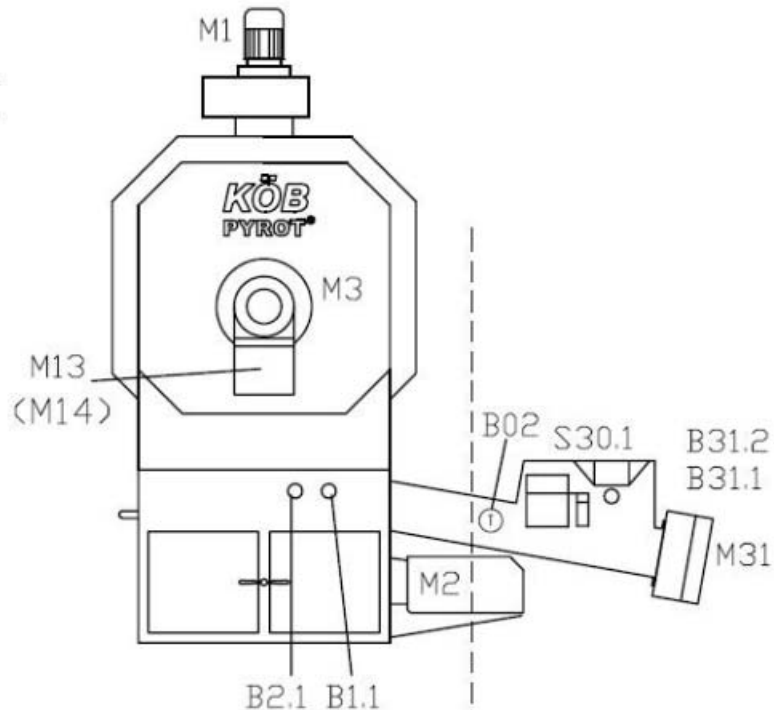

**+KRT**

**+Txx**

Previous page: 101

Next page: 103

Rev.	Description	Date
2		
1		
		Date: 11.09.15



Viessmann Manufacturing Company Inc.  
750 McMurray Road,  
Waterloo, Ontario N2V 2G5

Project name: Oakland University

Page title: Boiler lay-out

Project No.:  
**PRJ-00240**

Page: 102 of: 103



## Spring-operated extraction system T32

## Loader module T31

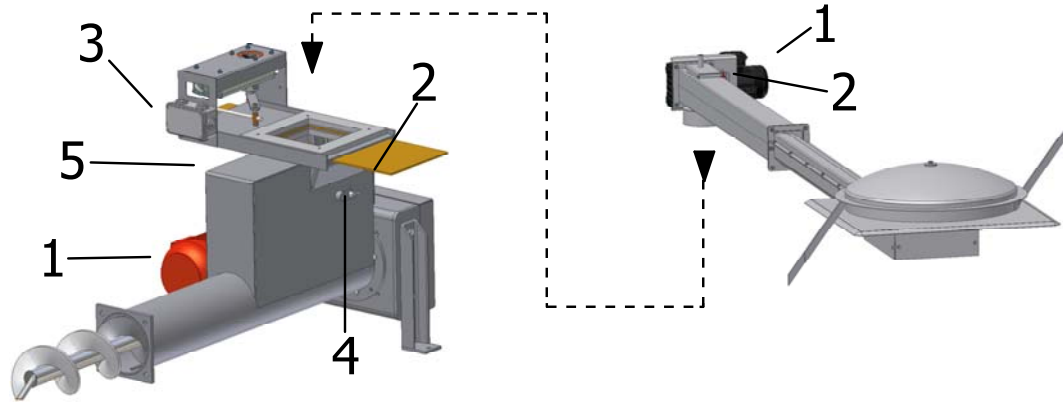

- 1- Motor M31
- 2- Limit switch for maintenance cover S31.1
- 3- Slide valve T30
- 4- Light barrier B31.1 (transmitter)
- 5- Light barrier B31.2 (receiver)

- 1- Motor M32
- 2- Limit switch for maintenance cover S32.1
- 3- Limit switch for silo door S32.2

2		
1	Add T32	12.01.12
Rev.	Description	Date
		Date: 11.04.01