

1 Setup – Remove Stand

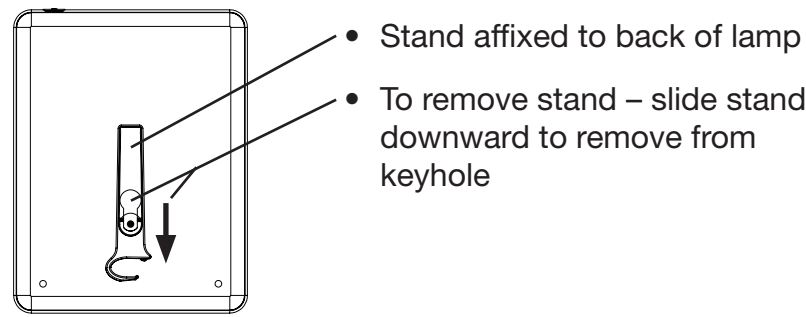

- Stand affixed to back of lamp
- To remove stand – slide stand downward to remove from keyhole

2 Setup – Affix Stand - vertical

Affix stand by clipping to bottom left or bottom right – as shown.

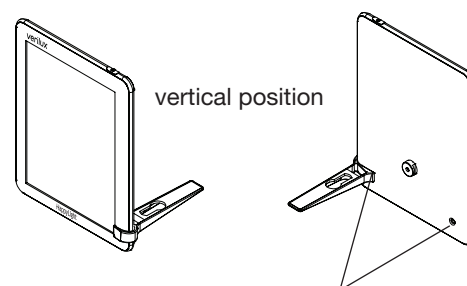

3 Setup – Affix Stand - horizontal

Stand can be attached so lamp orientation is horizontal.

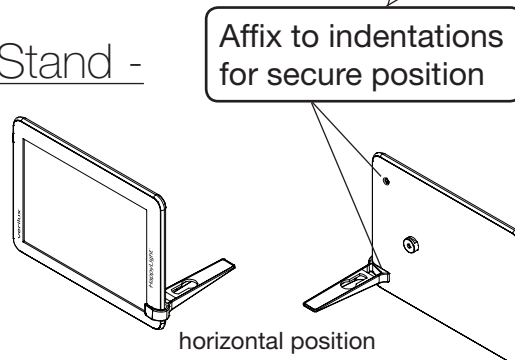

Affix to indentations for secure position

1

horizontal position

Minimum Recommended Program

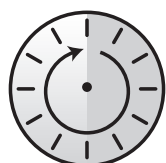

30 minutes to 1 hour* / day

Researchers at the National Institute of Health demonstrated that white light, in a range of 2,500 to 10,000 LUX (a measurement of light intensity), helped to reverse the symptoms of “Winter Blues.”

Exposure strategies affect people differently. We all have different reactions to our environment. It is important to establish a distance and schedule that is comfortable for you. We recommend you use the light regularly and at about the same time each day. It is not necessary to sit in front of the lamp continuously. You can divide the time into several mini-sessions. Continue to use the HappyLight daily to feel an improvement in your mood and activity level.

When you are feeling sluggish and lethargic, spend more time with the light or sit closer to it. If you feel a sort of edginess, as though you have consumed too much coffee, it may be time to turn off the unit.

* Recommended exposure time is a function of output and distance. Individual results may vary. Also, refer to the warnings at the bottom of the Device Pretest section of this manual.

⚠ WARNING: Certain medications (e.g., anti-depressants) and diagnosed mental health conditions may induce light sensitivity, which may result in discomfort, hyperactivity, or hypomania. Consult with your healthcare provider before using this product.

⚠ WARNING: If you have a pre-existing eye condition, or are at risk for developing Age Related Macular Degeneration or other eye conditions consult with your healthcare provider before using this product.

5

4 How To Use

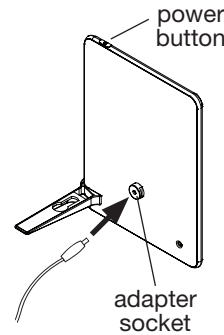

- Place lamp on a flat level surface
- Insert power adapter plug into the adapter socket – as shown on rear of HappyLight®
- Plug adapter in to a standard 110 AC electrical outlet
- Turn on the lamp

5 How To Use – continued

Use consists of sitting close to the HappyLight with your eyes open. While staying oriented toward the light, feel free to engage in other activities such as reading, writing, hobbies and crafts, sewing, needlepoint, applying make-up or working at your computer or desk.

The HappyLight should be positioned as close as 6 inches, but within 24 inches of your face and should be slightly off-center. (See diagram.) *Note: Do not look directly into the lamp.*

The light from the HappyLight must be directed at your eyes; therefore, your eyes must be open to achieve the full benefit. *Note: Tinted glasses reduce the amount of light reaching your eyes.*

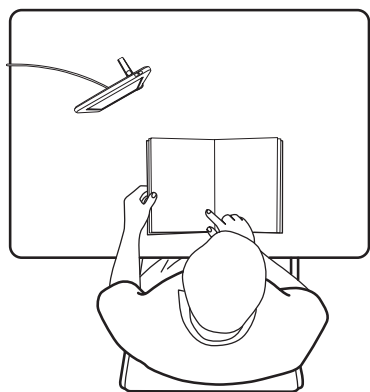

2

6 How To Use – continued

When you are feeling sluggish and lethargic, spend more time with the light or sit closer to it. If you experience edginess or are over-stimulated, move the light farther away or reduce session times.

⚠ CAUTION: Do not run the power cord over the top of the lamp. Always place it behind the lamp.

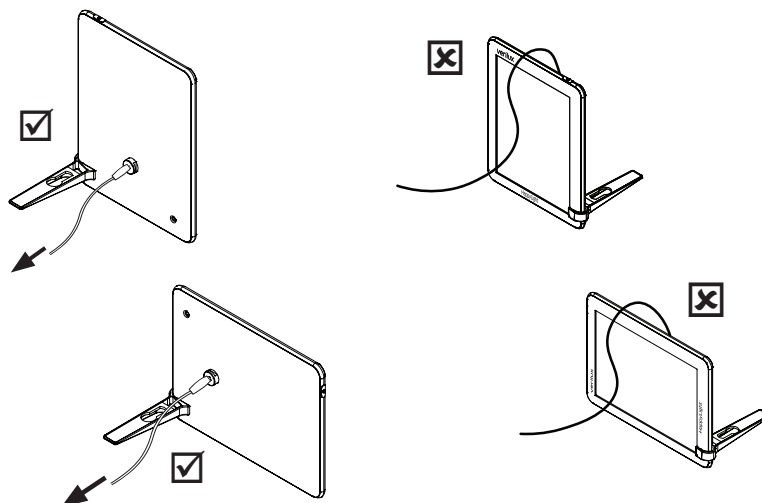

3

Important Safeguards — continued

⚠ CAUTION: — continued

- Do not run the power cord over the top of the lamp. Always place it behind the lamp.
- This lamp may cause interference with radios, cordless telephones or devices that use a wireless remote control, such as televisions. If interference occurs, move the lamp away from the device, plug the lamp or the device into a different outlet or move the lamp out of the line of sight of the remote control receiver.†
- This lamp is not for use with light dimmers, timers, motion detectors, voltage transformers or extension cords.
- Never cover the lamp or place anything on top of it when it is in operation.

SAVE THESE INSTRUCTIONS

† This device complies with Part 15 of the FCC Rules. Operation is subject to the following two conditions: (1) this device may not cause harmful interference, and (2) this device must accept any interference received, including interference that may cause undesired operation.”

This Class B digital apparatus complies with Canadian ICES-005.

Features

Your new Verilux HappyLight LED Energy Lamp is a remarkable product with many features and benefits. It:

- Delivers Natural Spectrum® light to your home, office, dorm room or apartment.
- Cues your body's own energy enhancers to make you more alert and productive.
- Has up to 10,000 Lux* of bright Natural Spectrum light to lift spirits, sharpen concentration and improve energy levels.
- Is designed with a compact shape and small footprint to make it easy to place in a convenient location.

*10,000 Lux (photopic measurement) at 6”.

7

Device Pretest

To help determine if you have sensitivity to light treatment, we recommend that you perform this pretest upon first use of this device:

Step 1 - Turn on the lamp and position it about 18 inches from your face. (Do not look directly into the lamp.)

Step 2 - Operate the lamp for approximately 10 minutes and turn it off. If the light has caused any discomfort, stop using the lamp and consult a doctor. If you have no discomfort, you may consider gradually decreasing the distance from the lamp and increasing the use time, which results in more lamp intensity and greater effect. For your initial sessions, you should monitor the degree of any discomfort and accordingly adjust the time used and lamp location.

⚠ WARNING: Certain medications (e.g., anti-depressants) and diagnosed mental health conditions may induce light sensitivity, which may result in discomfort, hyperactivity, or hypomania. Consult with your healthcare provider before using this product.

⚠ WARNING: If you have a pre-existing eye condition, or are at risk for developing Age Related Macular Degeneration or other eye conditions consult with your healthcare provider before using this product.

⚠ WARNING: Individuals diagnosed with mental health issues should contact their physician prior to use of this product. Over exposure to light therapy may lead to hypomania.

4

Care and Cleaning

Your lamp is made from high-quality materials that will last for many years with minimum care. You may want to periodically clean the lamp using a mild non-abrasive cleaner and soft cloth. When cleaning, make sure you have turned off and unplugged the unit and allowed sufficient time for the unit to cool.

Troubleshooting

Before requesting service on your Verilux lamp, please:

- Make sure all power connectors, cords and plugs are inserted fully and securely.
- Make sure there is power to the wall outlet, or try another outlet – one that is not connected to a dimmer.

PROBLEM	CHECK	SOLUTION
Light Won't Come On	Has the plug come loose?	Insert plug securely into wall outlet. Insert plug securely into the back of the unit.
Light Flickers	Has the plug come loose?	Insert plug securely into wall outlet. Insert plug securely into the back of the unit.
	Is the lamp connected to a dimmer switch?	Connect lamp plug only to wall outlet without dimmer switch.

Technical Specifications

HappyLight Lucent LED

Environment: Operating Temperature: 10 to 35°C (50 to 95°F) Storage Temperature: -20 to 50°C (-4 to 122°F) Relative Humidity: 10 to 90% non-condensing

Power: Input Power to the Adapter: 100-240 VAC, 0.4A, 50/60Hz
Input Power to the Unit: DC19.2V, 0.65A

ETL Listed in Canada and the USA

8

ATTENTION! ONCE OPENED, PLEASE **DO NOT** RETURN THIS PRODUCT TO THE STORE WHERE IT WAS PURCHASED FOR REPAIR OR REPLACEMENT!

Many questions can be answered by visiting www.verilux.com, or you may call our Customer Service Department at 1-800-786-6850 during normal business hours.

This limited warranty is provided by Verilux, Inc., 340 Mad River Park, Waitsfield, VT 05673

Verilux warrants this product to be free from defects in material and workmanship for a period of three years from the date of the original retail purchase from Verilux or an authorized Verilux distributor. **Proof of purchase is required for all warranty claims.** During the limited warranty period, Verilux, Inc., will, at its option, repair or replace defective parts of this product at no charge to the customer, subject to these limitations: This limited warranty does not include any postage, freight, handling, insurance or delivery fees. This warranty does not cover damage, defect or failure caused by or resulting from accident, external destruction, alteration, modification, abuse, misuse or misapplication of this product.

This warranty does not cover damage to the product resulting from return shipping or handling. Shipping insurance is recommended to help protect your product.

Return Authorization is required for all returns. To obtain a Return Authorization, please contact the Verilux Customer Service Department at 1-800-786-6850.

If, during the first three years of ownership, this product fails to operate properly, it should be returned as specified at www.verilux.com/warrantyreplacement or as instructed by a Verilux customer service representative at 1-800-786-6850.

Note: Verilux recommends using a quality surge suppressor on all electronic equipment. Voltage variations and spikes can damage electronic components in any system. A quality suppressor can eliminate the vast majority of failures attributed to surges. Suppressors may be purchased at electronics stores.

Due to ongoing improvements, actual product may have slight variations from the product described in this manual.

Please visit our website at www.verilux.com or call our Customer Service Department at **1-800-786-6850**

Representatives are available Monday – Friday, 9am – 5pm EST

verilux

340 Mad River Park, Waitsfield, VT 05673

Register warranty online at: verilux.com/warranty

Printed in China for: Verilux, Inc.

© Copyright 2018 Verilux, Inc. All rights reserved.

VT22_MAN_Rev3

9